

### ***Gb (8M×8Bank×16) Double DATA RATE 2 SDRAM AC Timing***

#### **Contents**

1. Bank Activate Command
2. Read Burst Timing
3. Read followed by a write to the same bank I
4. Read followed by a write to the same bank II
5. Read followed by a write to the same bank III
6. Basic Burst Read Timing
7. Burst Read Operation
8. Burst Read Operation
9. Burst Read followed by BurstWrite
10. Seamless Burst Read Operation I
11. Seamless Burst Read Operation II
12. Basic Burst Write Timing
13. Burst Write Operation I
14. Burst Write Operation II
15. Burst Write followed by Burst Read
16. Seamless Burst Write Operation I
17. Seamless Burst Write Operation II
18. Write Data Mask Timing
19. Burst Write Operation with Data Mask
20. Read Burst Interrupt Timing
21. Write Burst Interrupt Timing
22. Burst Read Followed by Precharge I
23. Burst Read Followed by Precharge II
24. Burst Read Followed by Precharge III
25. Burst Read Followed by Precharge IV
26. Burst Read Followed by Precharge V
27. Burst Write followed by Precharge I
28. Burst Write followed by Precharge II
29. Burst Read with Auto-Precharge I
30. Burst Read with Auto-Precharge II
31. Burst Read with Auto-Precharge III
32. Burst Read with Auto-Precharge IV
33. Burst Write with Auto-Precharge I
34. Burst Write with Auto-Precharge II
35. Auto-Refresh Command
36. Self-Refresh Command
37. Active Power-Down Mode Entry I
38. Active Power-Down Mode Entry II
39. Active Power-Down Mode Entry III
40. Precharge Power Down Mode Entry and Exit

1. Bank Activate Command:  $t_{RCD}=3$ ,  $AL=2$ ,  $t_{RP}=3$ ,  $t_{RRD}=2$

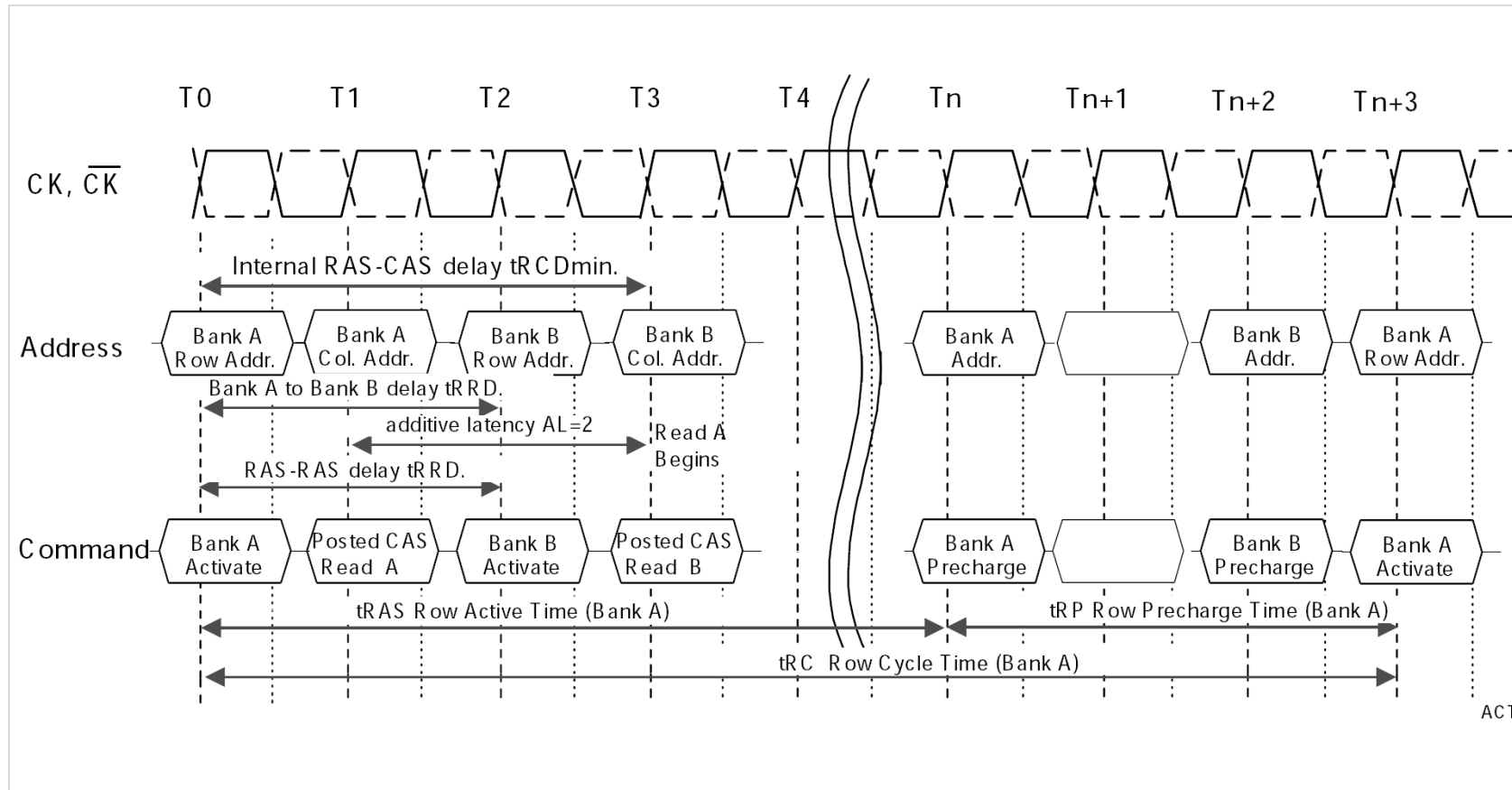

2. Read Burst Timing: CL=3, AL=0, RL=3, BL=4

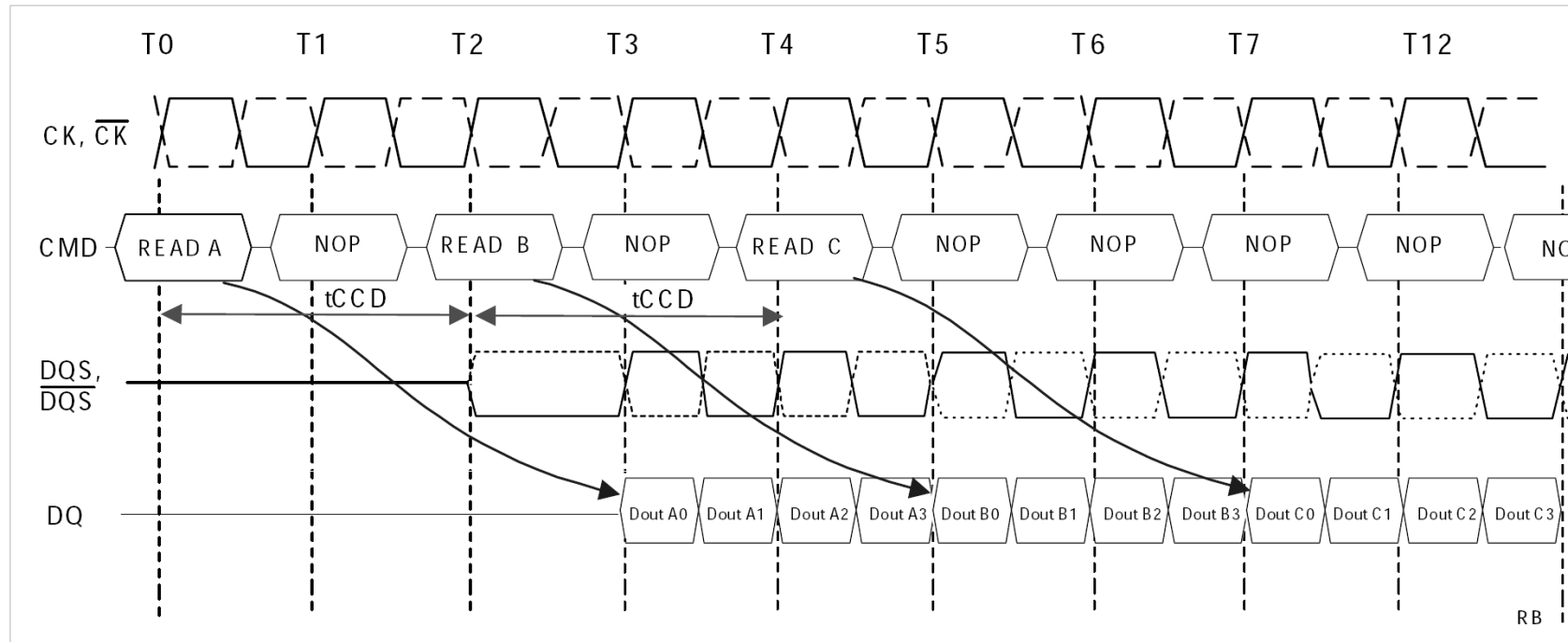

**3. Read followed by a write to the same bank I: Activate to Read delay < tRCDmin**

AL = 2 and CL = 3, RL = (AL + CL) = 5, WL = (RL - 1) = 4, BL = 4

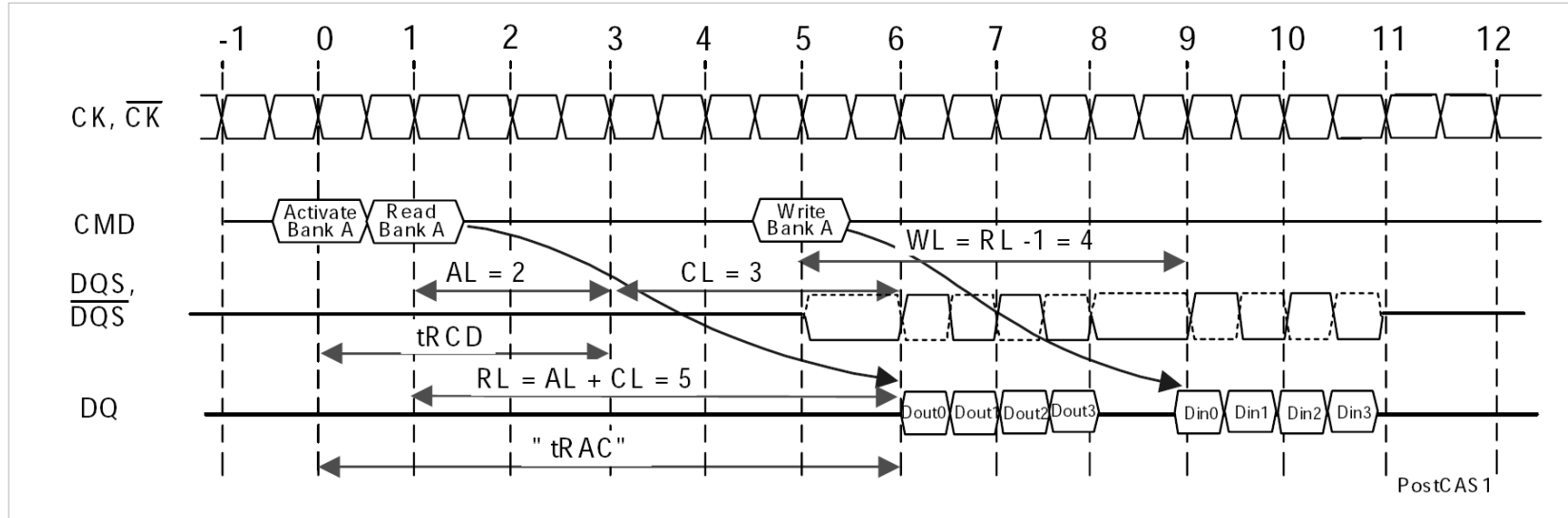

**4. Read followed by a write to the same bank II: Activate to Read delay < tRCDmin**

AL = 2 and CL = 3, RL = (AL + CL) = 5, WL = (RL - 1) = 4, BL = 8

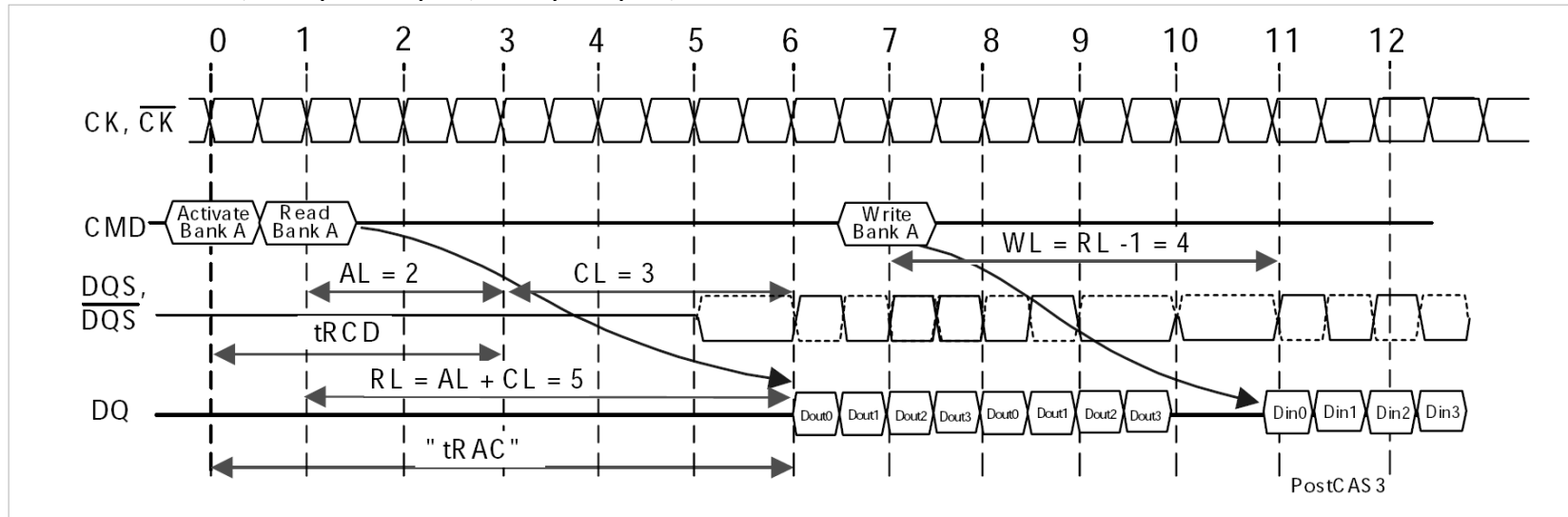

5. Read followed by a write to the same bank III: Activate to Read delay <  $t_{RC Dmin}$

AL = 1, CL = 3, RL = 4, WL = 3, BL = 4

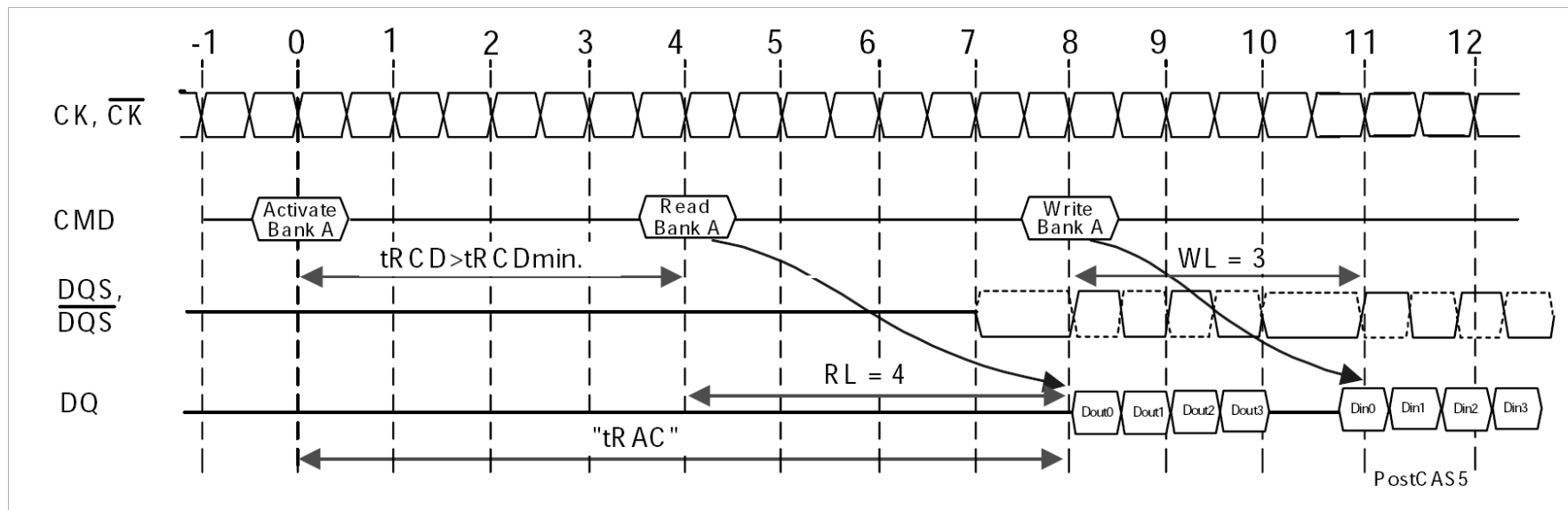

6. Basic Burst Read Timing

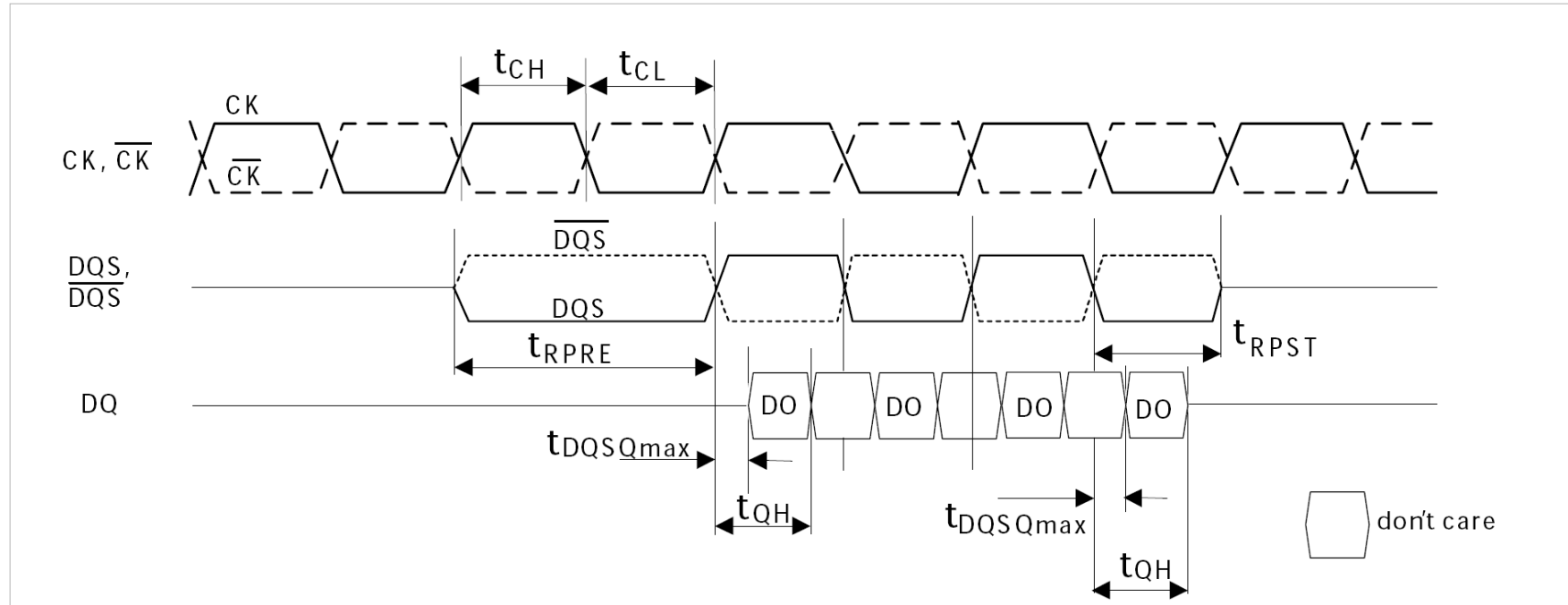

7. Burst Read Operation: RL = 5 (AL = 2, CL = 3, BL = 4)

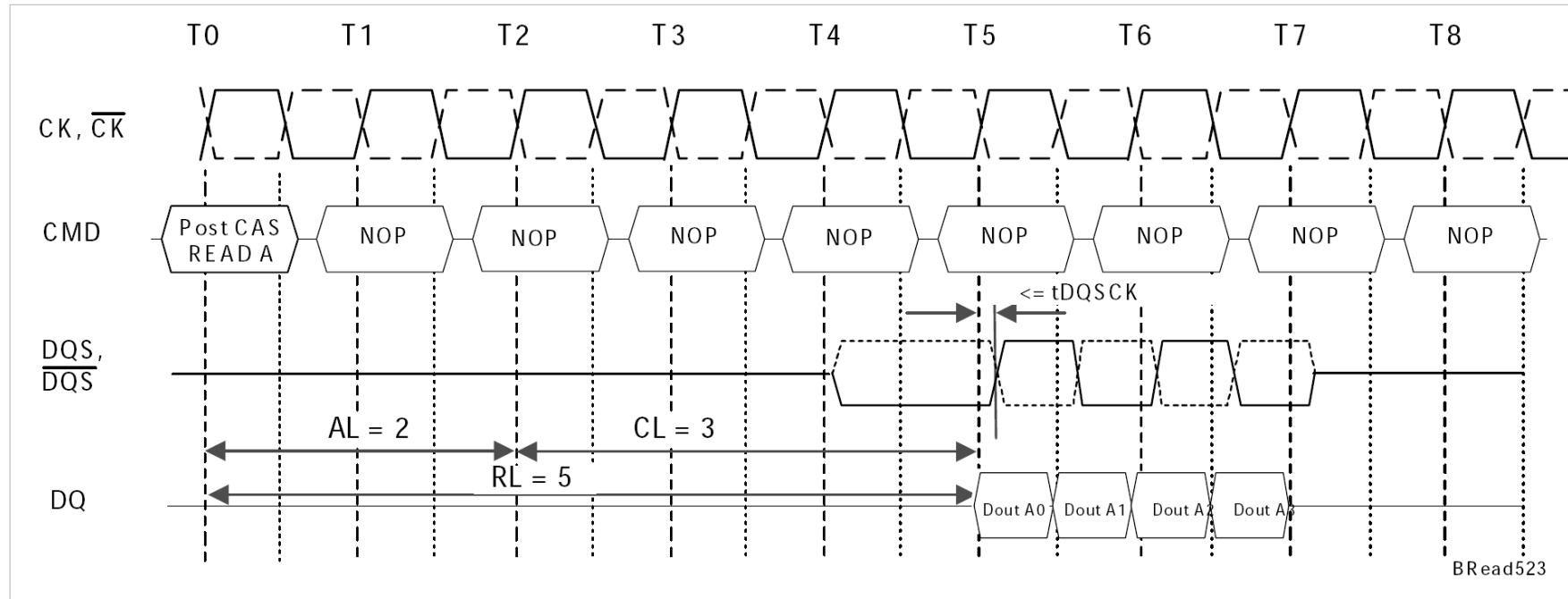

8. Burst Read Operation: RL = 3 (AL = 0, CL = 3, BL = 8)

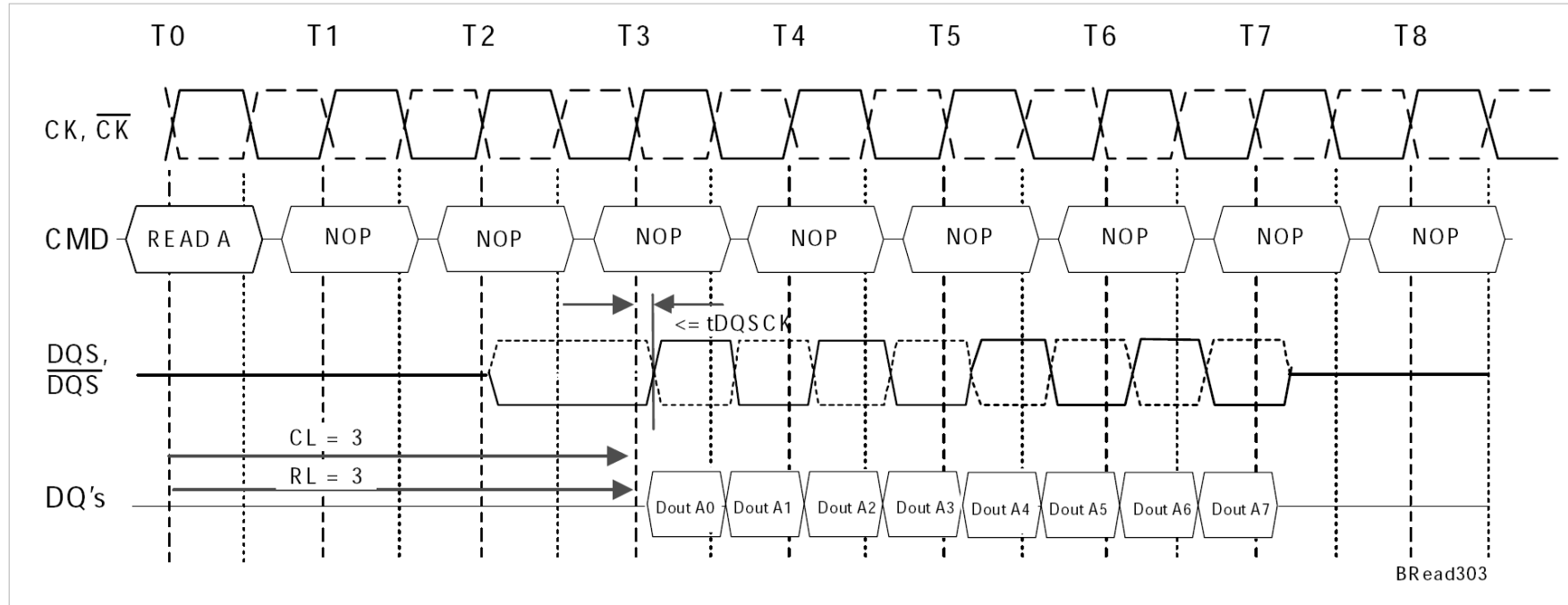

9. Burst Read followed by BurstWrite :  $RL = 5, WL = (RL-1) = 4, BL = 4$

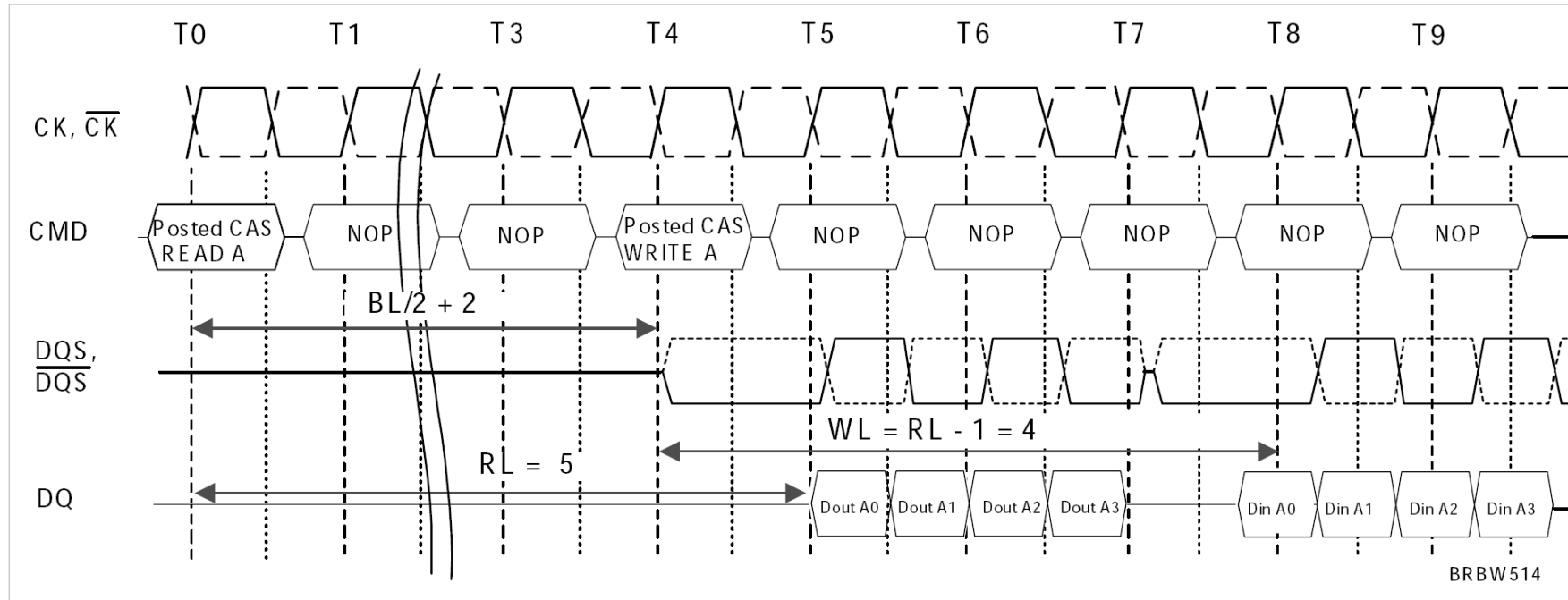

The minimum time from the burst read command to the burst write command is defined by a read-to-write turn-around time, which is  $BL/2 + 2$  clocks.

10. Seamless Burst Read Operation I:  $RL = 5, AL = 2, CL = 3, BL = 4$

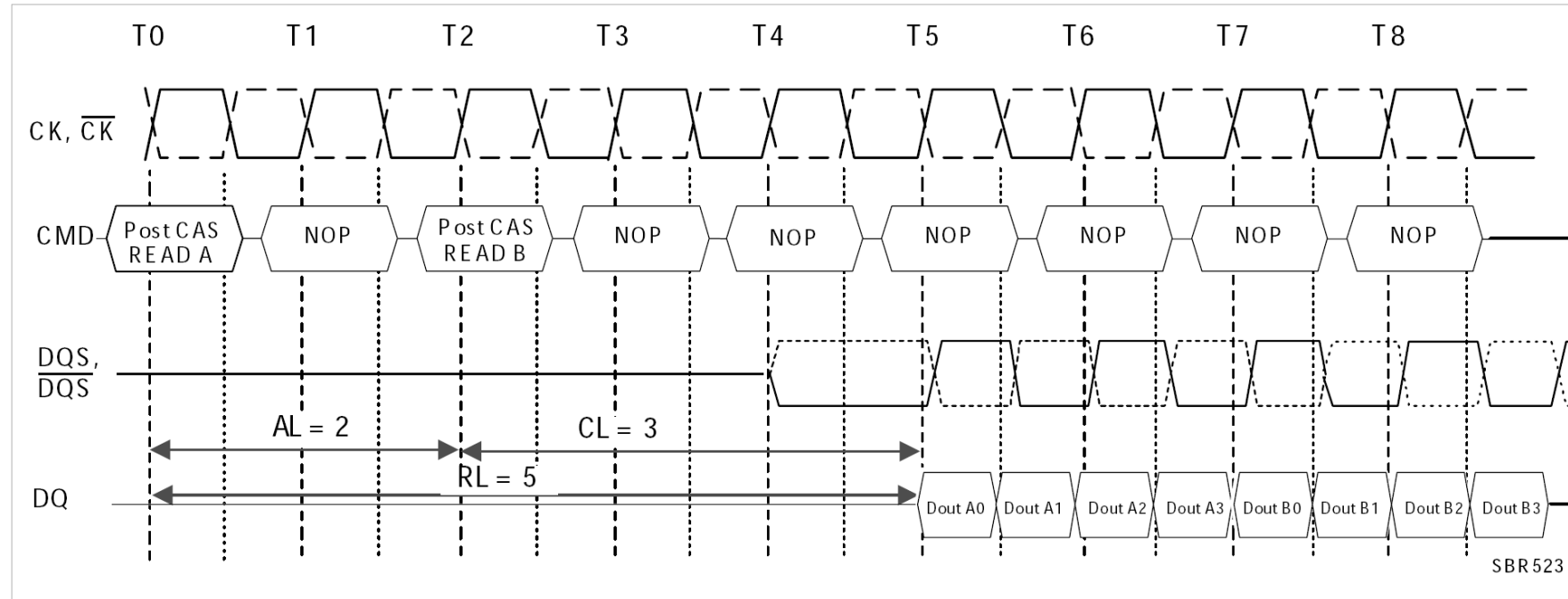

11. Seamless Burst Read Operation II:  $RL = 3, AL = 0, CL = 3, BL = 8$  (non interrupting)

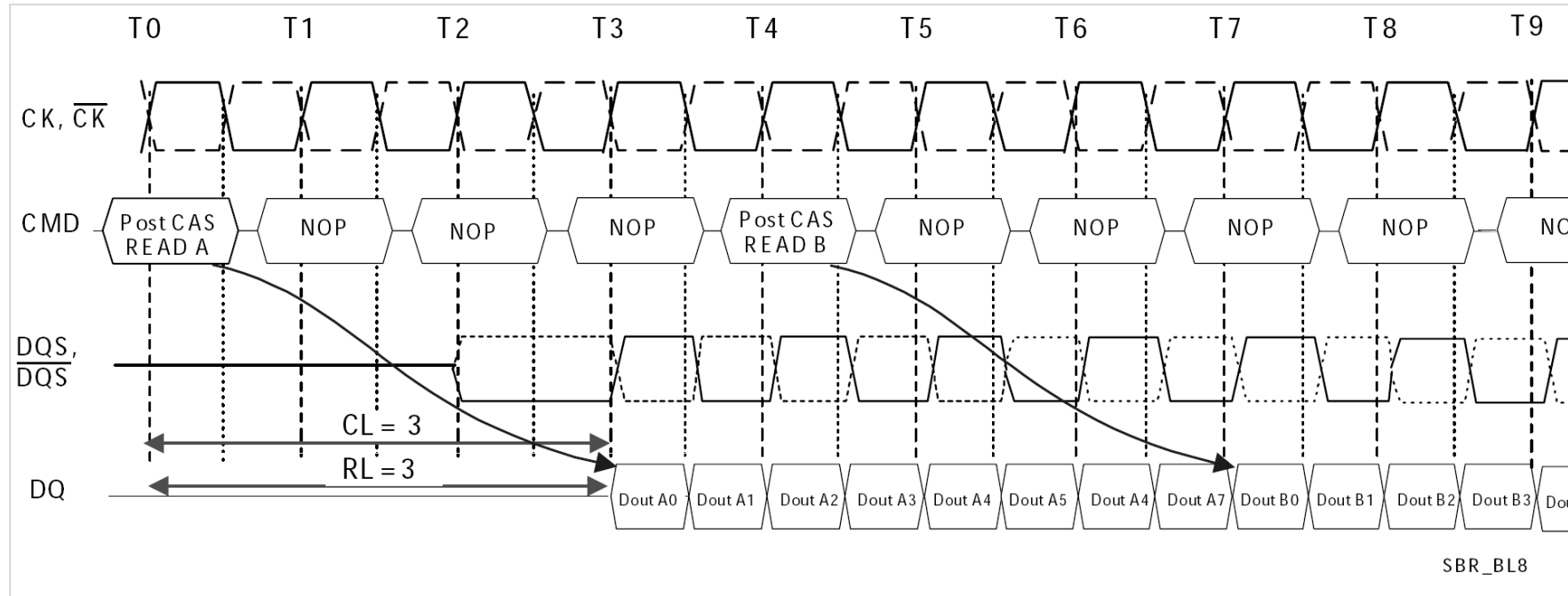

12. Basic Burst Write Timing

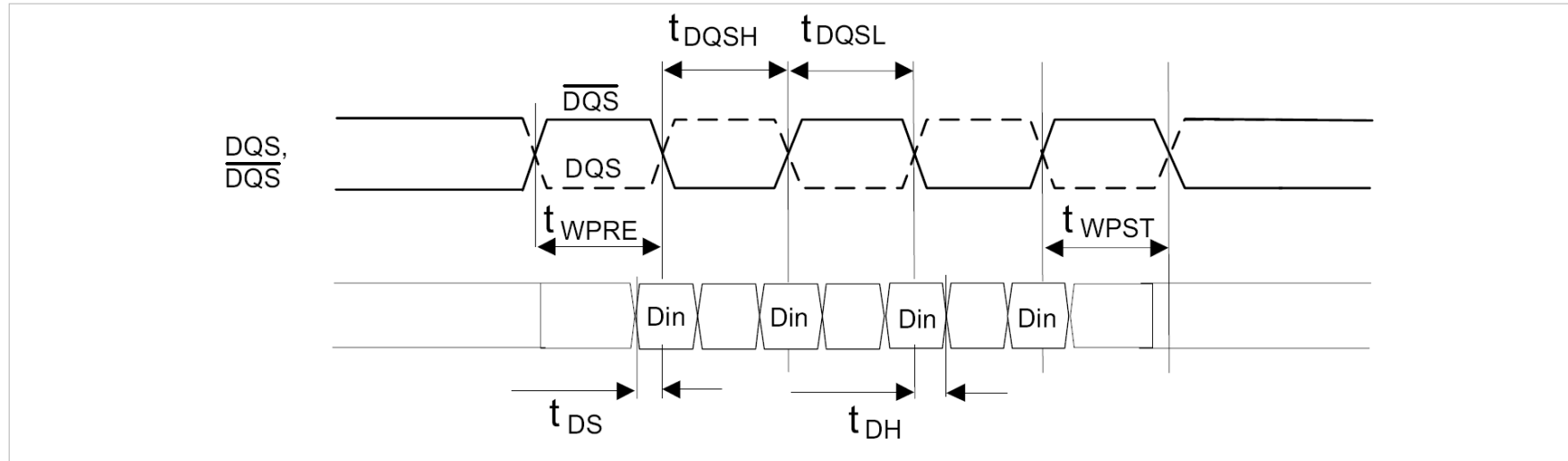

13. Burst Write Operation I:  $RL = 5$  ( $AL = 2, CL = 3$ ),  $WL = 4, BL = 4$

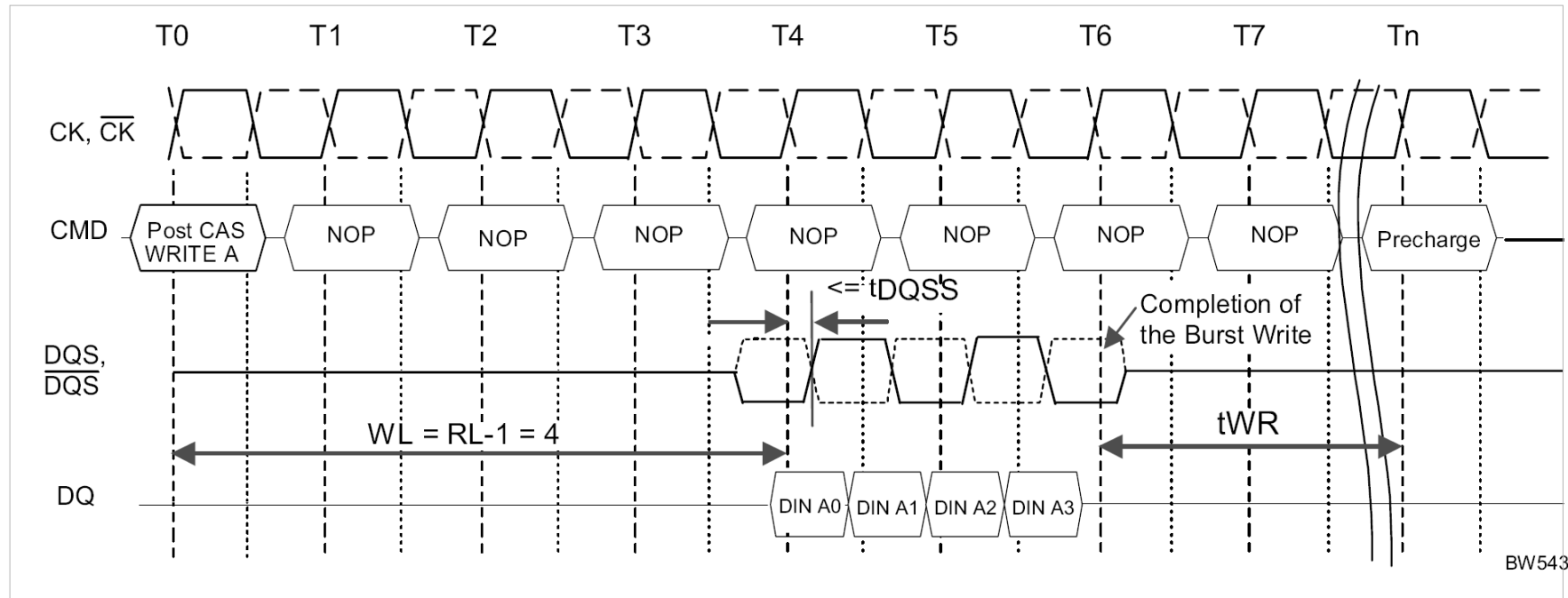

14. Burst Write Operation II:  $RL = 3$  ( $AL = 0, CL = 3$ ),  $WL = 2, BL = 4$

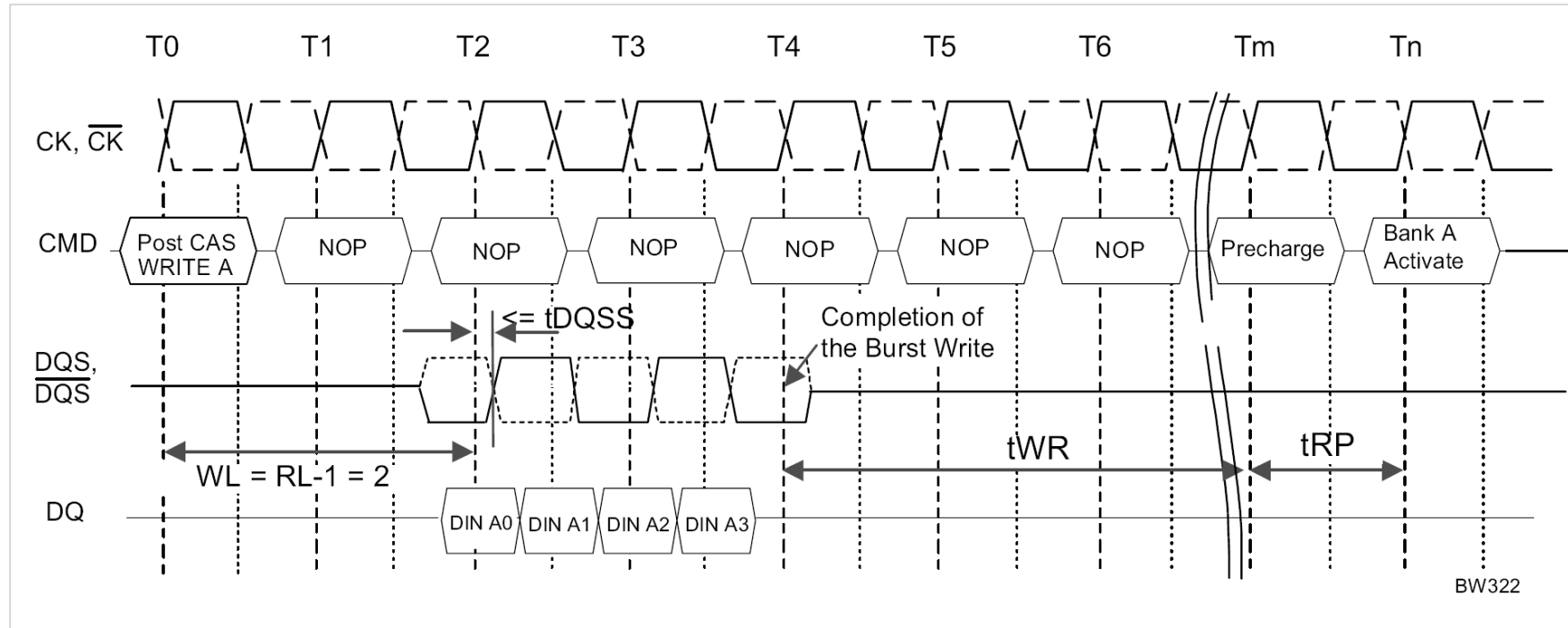

15. Burst Write followed by Burst Read:  $RL = 5$  ( $AL = 2$ ,  $CL = 3$ ),  $WL = 4$ ,  $tWTR = 2$ ,  $BL = 4$

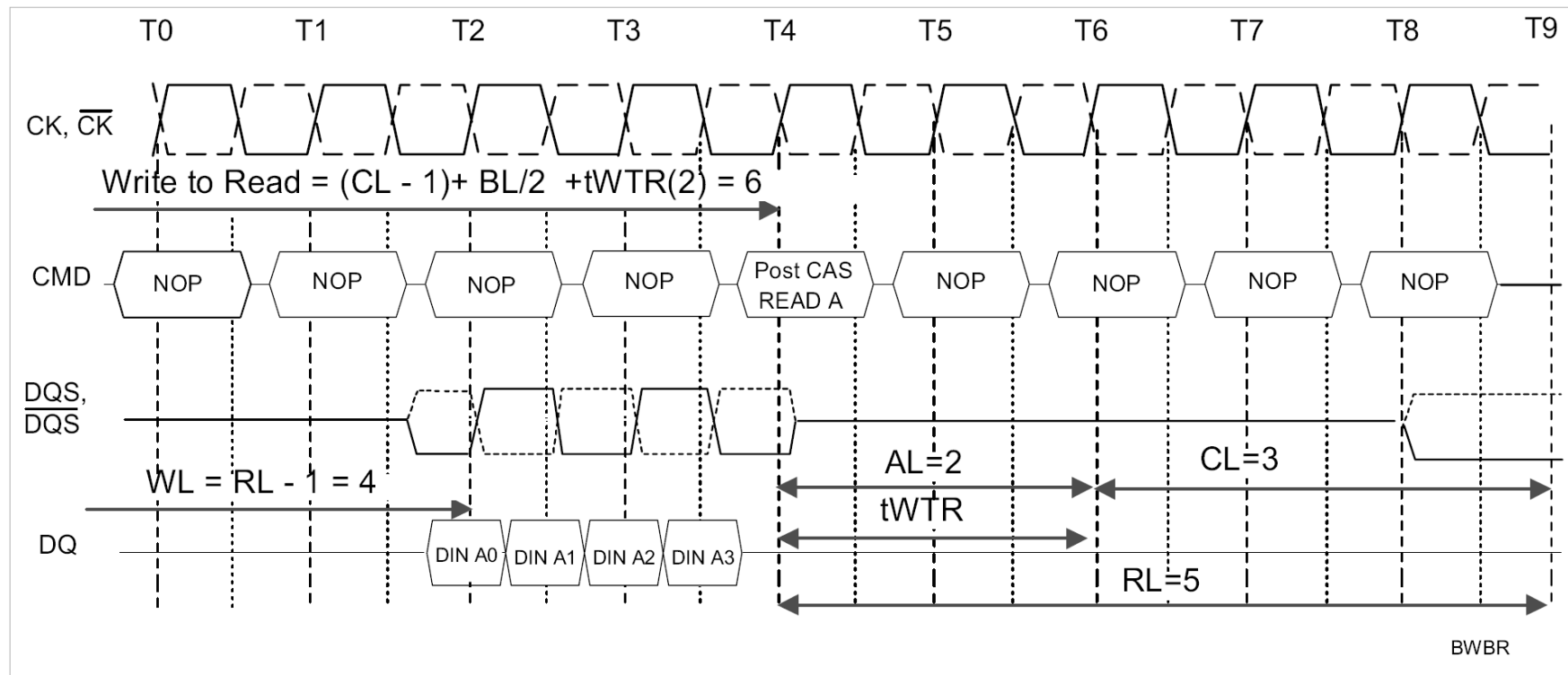

The minimum number of clocks from the burst write command to the burst read command is  $(CL - 1) + BL/2 + tWTR$  where  $tWTR$  is the write-to-read turn-around time  $tWTR$  expressed in clock cycles. The  $tWTR$  is not a write recovery time ( $tWR$ ) but the time required to transfer 4 bit write data from the input buffer into sense amplifiers in the array.

16. Seamless Burst Write Operation I:  $RL=5, WL=4, BL=4$

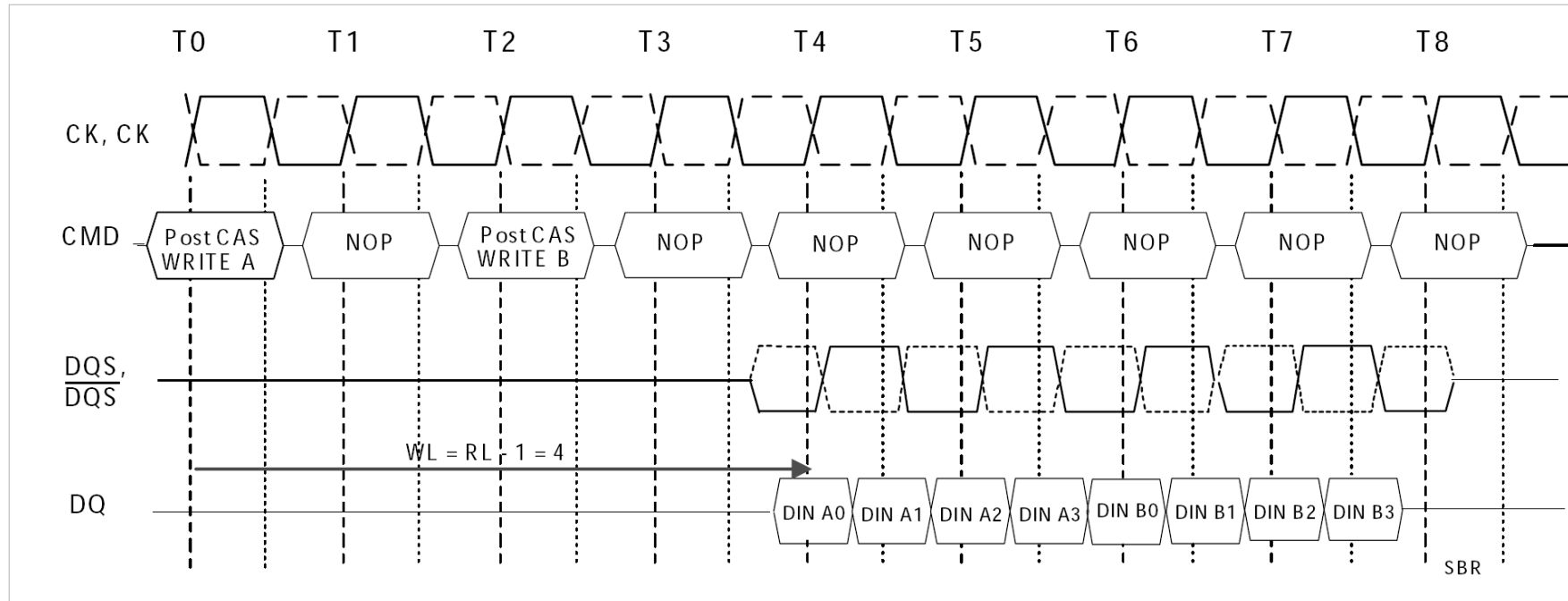

17. Seamless Burst Write Operation II: RL=3, WL=2, BL=8, non-interrupting

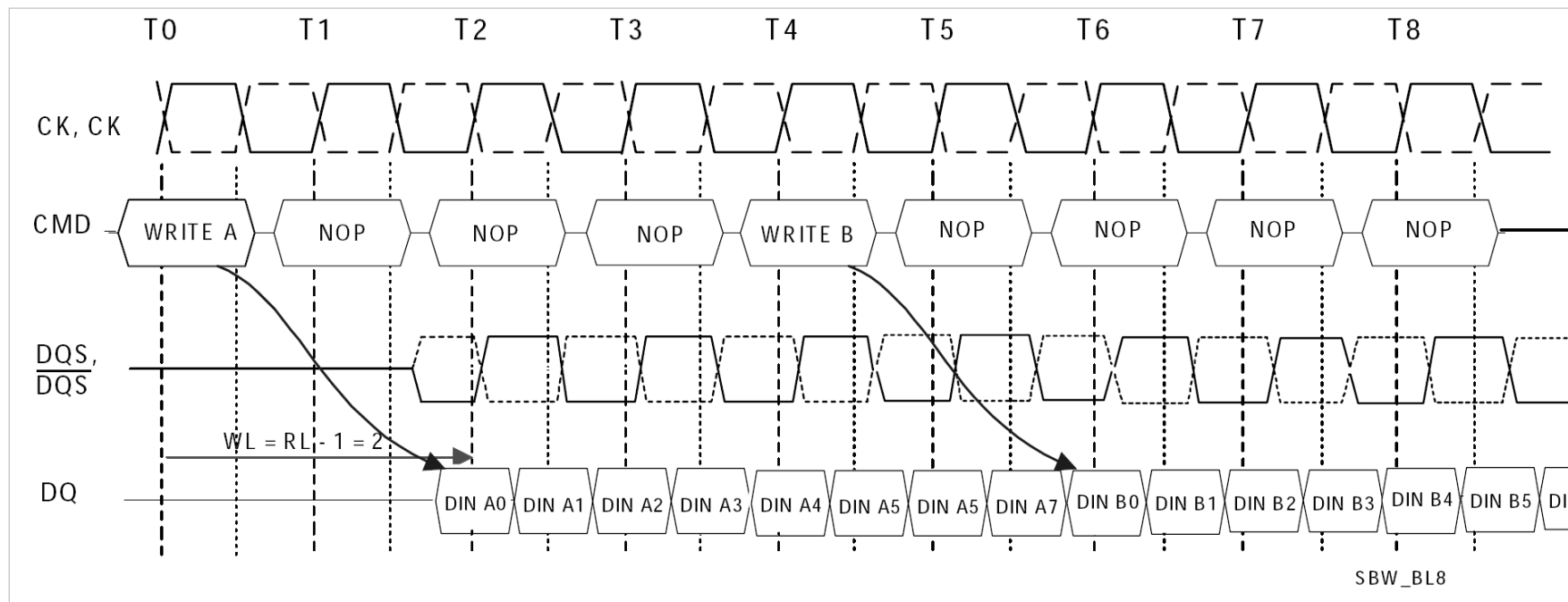

18. Write Data Mask Timing

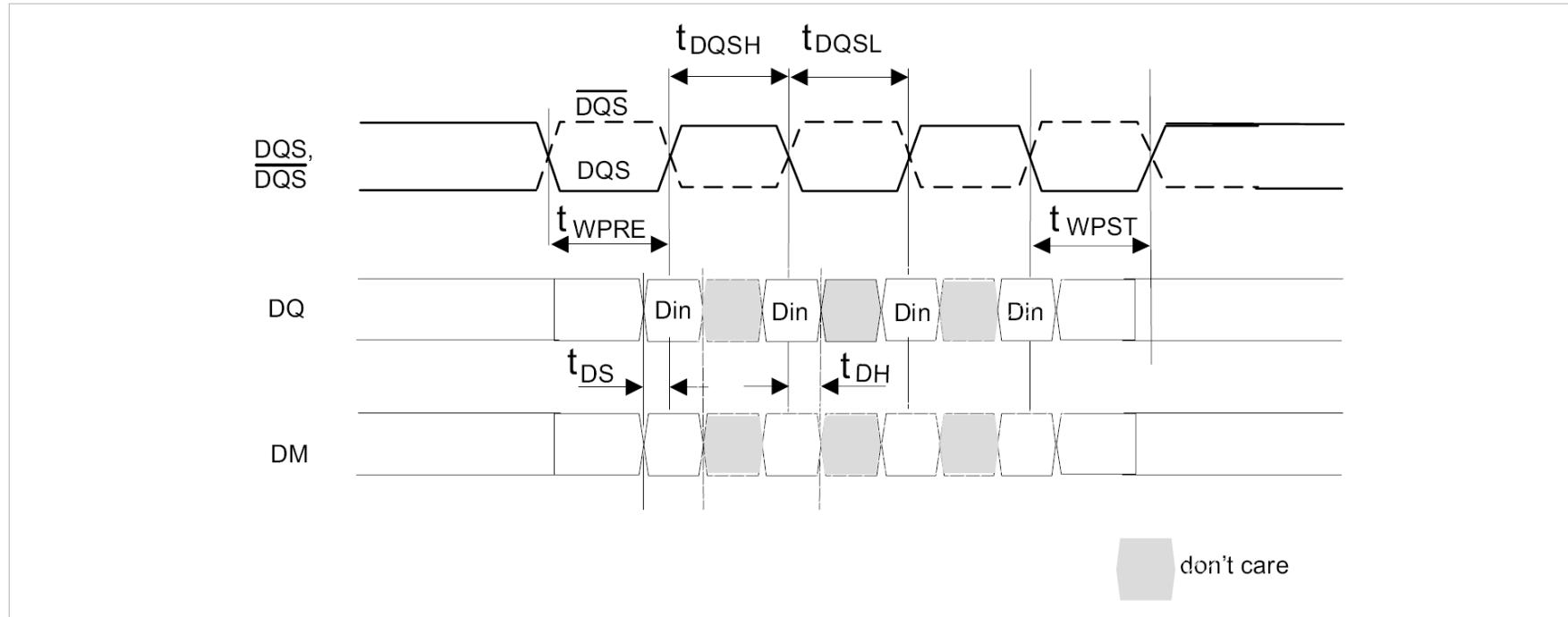

19. Burst Write Operation with Data Mask:  $RL = 3$  ( $AL = 0, CL = 3$ ),  $WL = 2$ ,  $tWR = 3$ ,  $BL = 4$

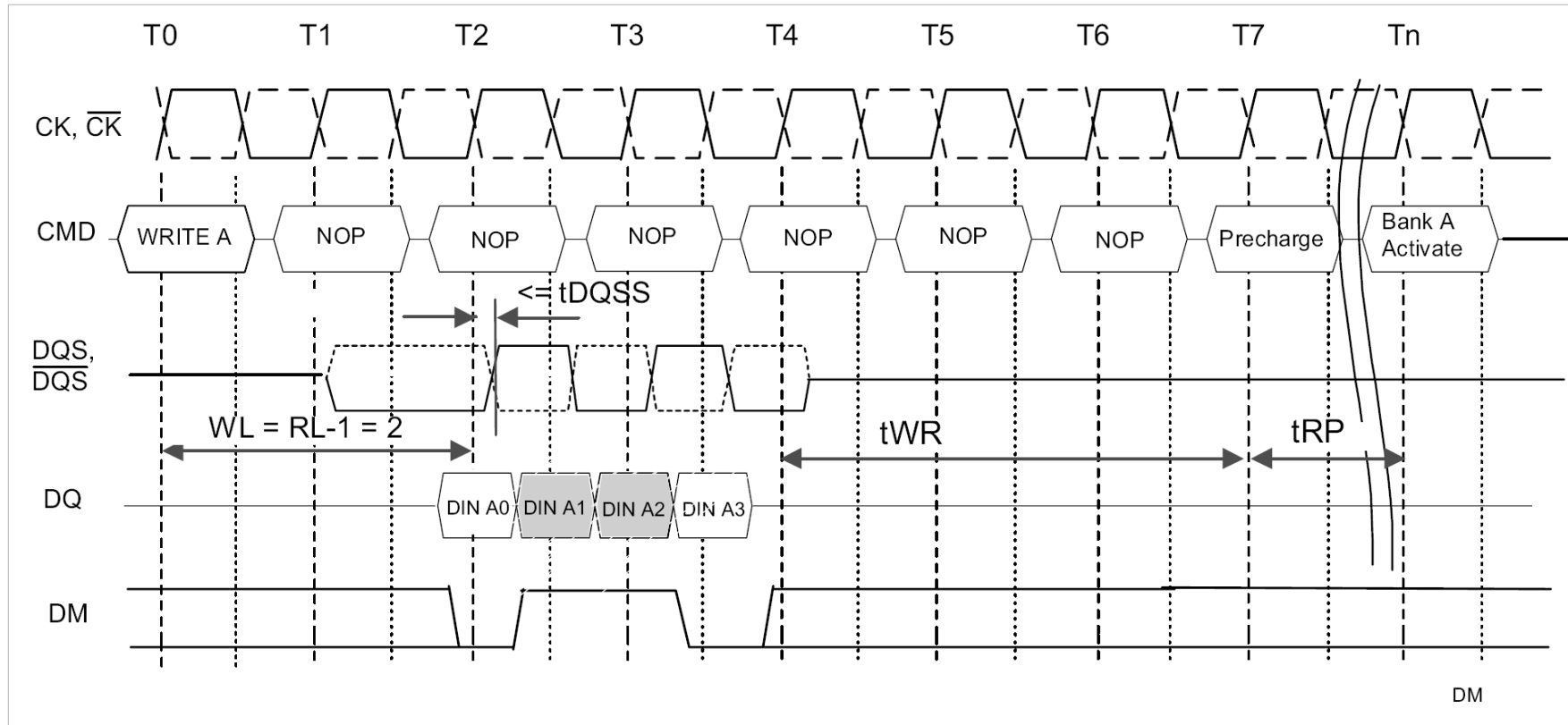

20. Read Burst Interrupt Timing: (CL = 3, AL = 0, RL = 3, BL = 8)

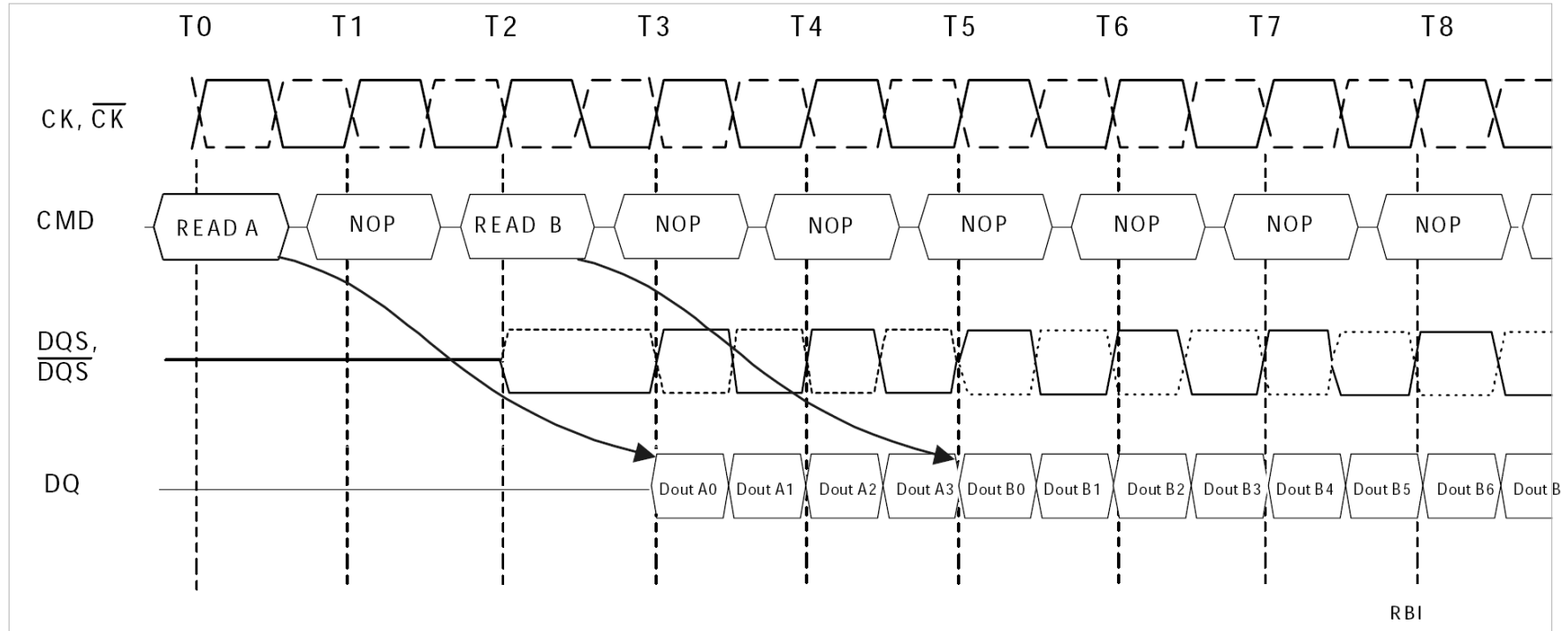

21. Write Burst Interrupt Timing: (C L = 3, AL = 0, WL = 2, BL = 8)

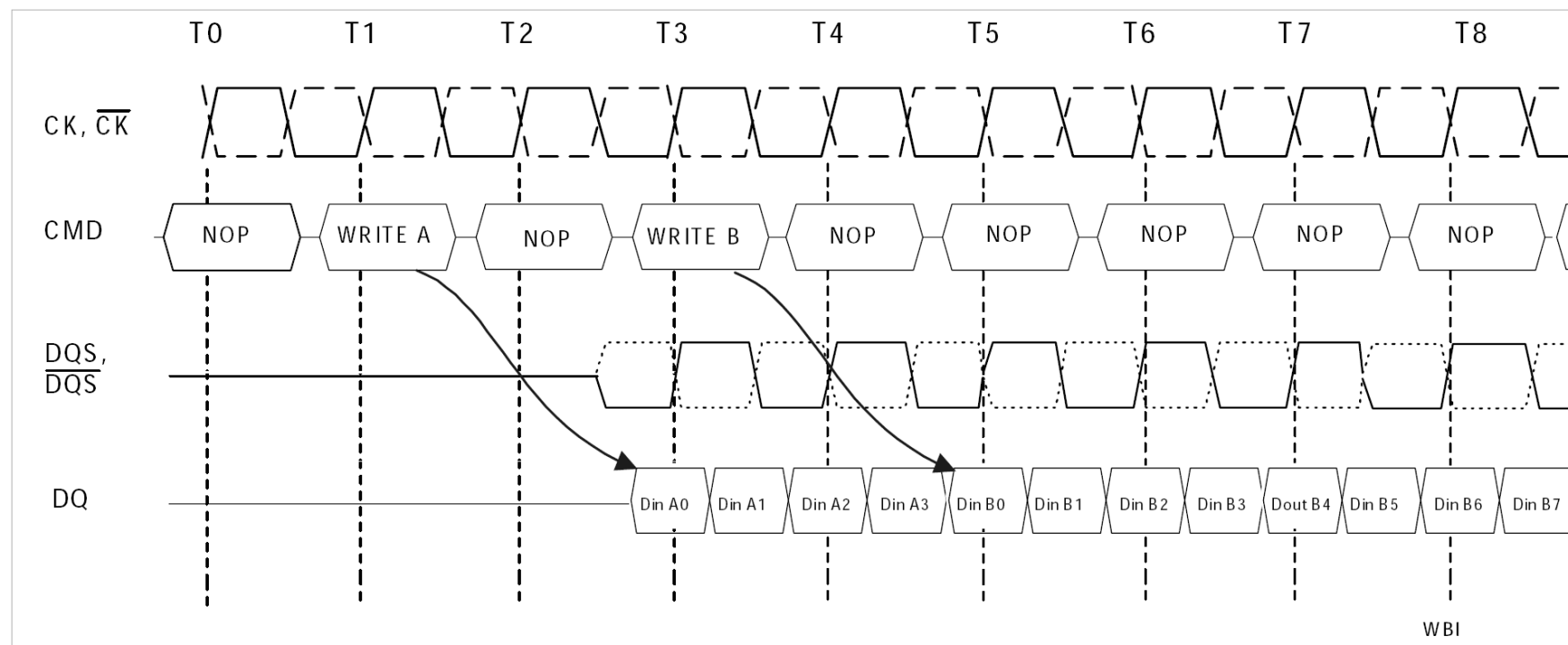

22. Burst Read Followed by Precharge I: RL = 4 (AL = 1, CL = 3), BL = 4, tRTP <= 2 clocks

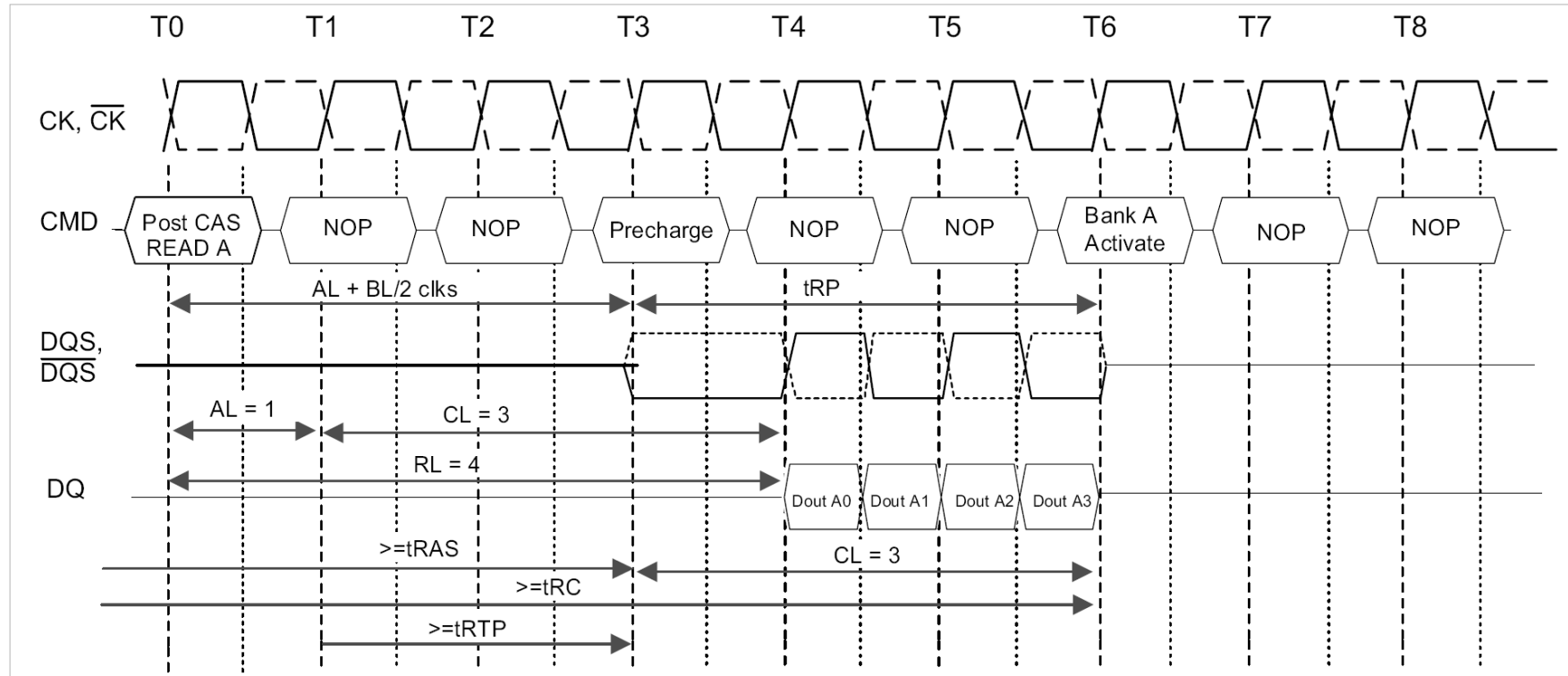

23. Burst Read Followed by Precharge II: RL = 4 (AL = 1, CL = 3), BL = 8, tRTP <= 2 clocks

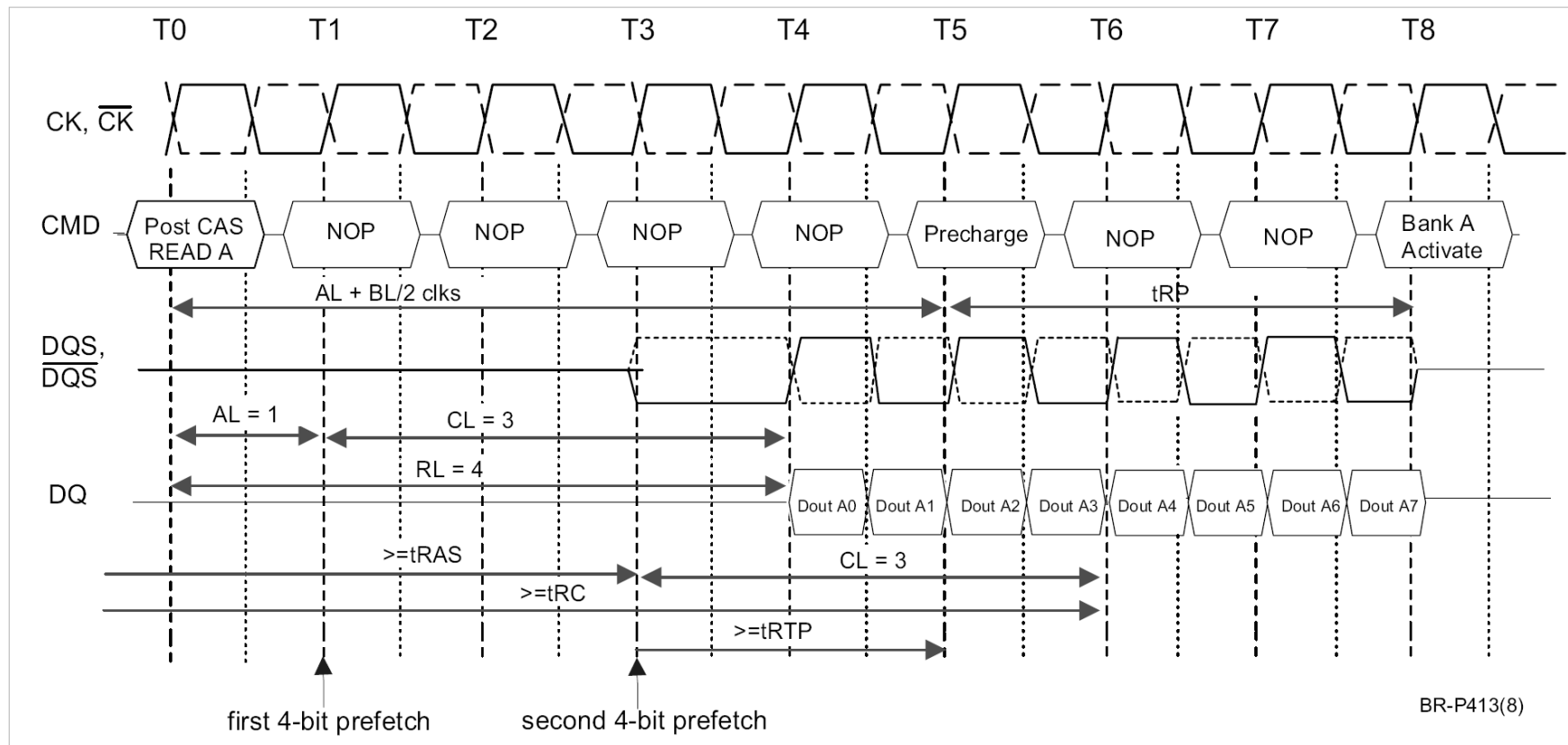

24. Burst Read Followed by Precharge III:  $RL=5(AL=2, CL=3)$ ,  $BL=4$ ,  $tRTP \leq 2$  clocks

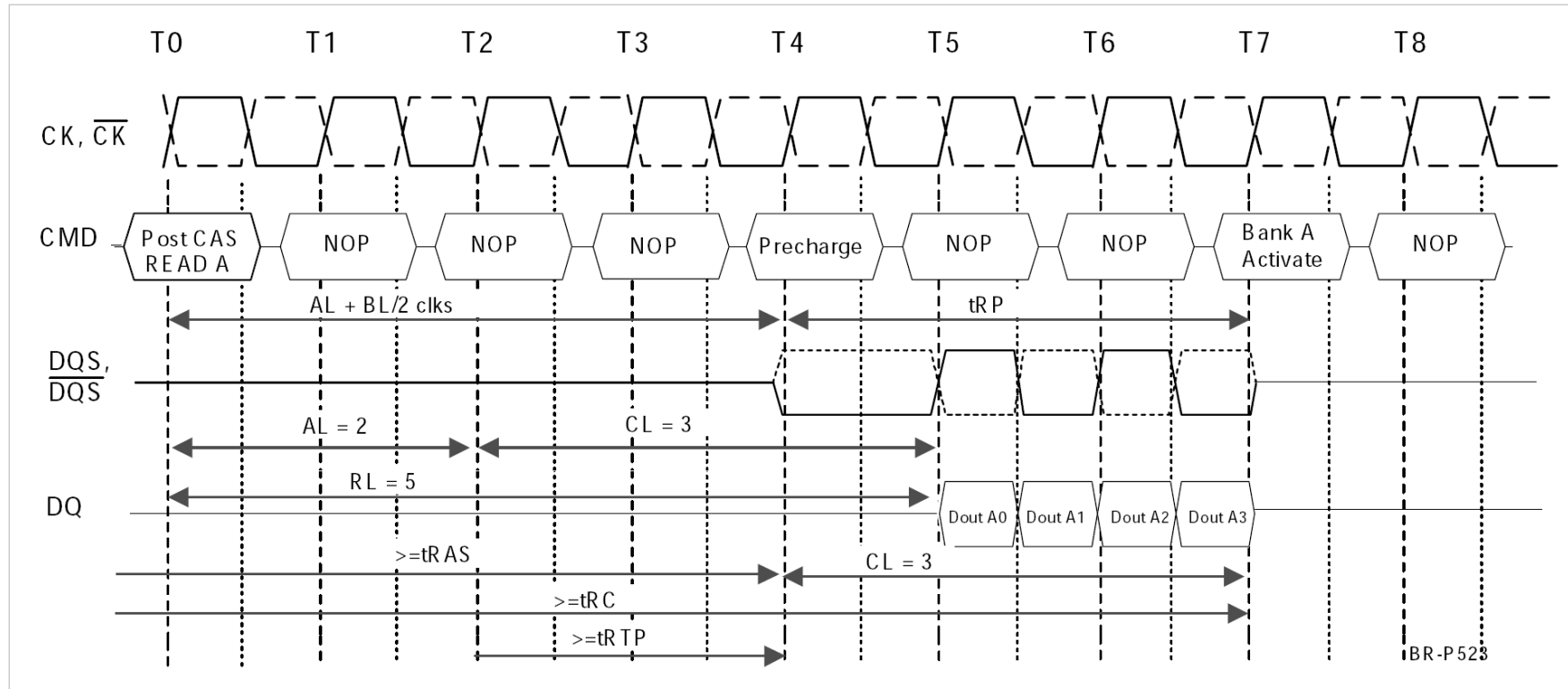

25. Burst Read Followed by Precharge IV:  $RL=6(AL=2, CL=4), BL=4, tRTP \leq 2$  clocks

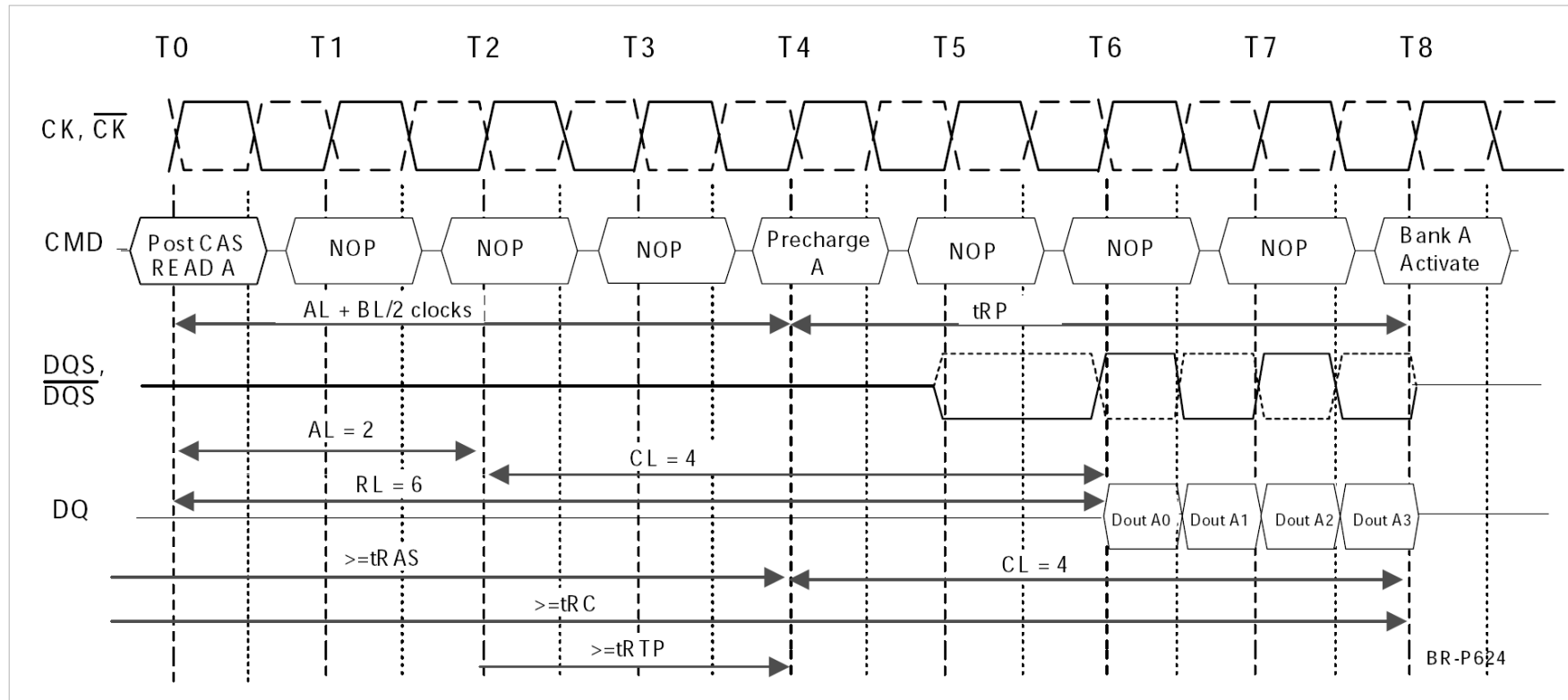

26. Burst Read Followed by Precharge V: RL=4, (AL=0, CL=4), BL=8, tRTP>2 clocks

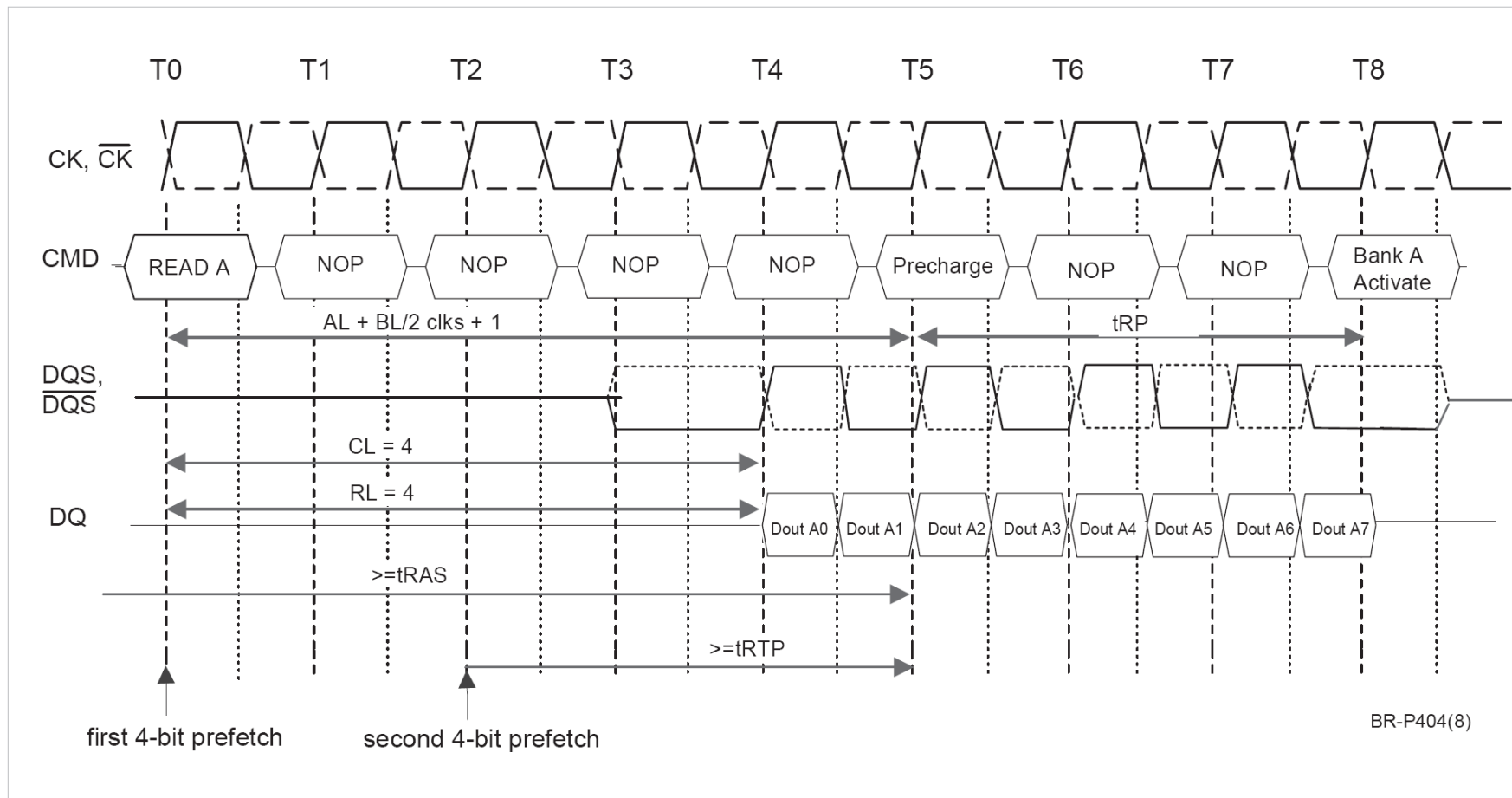

27. Burst Write followed by Precharge I:  $WL = (RL - 1) = 3, BL = 4, tWR = 3$

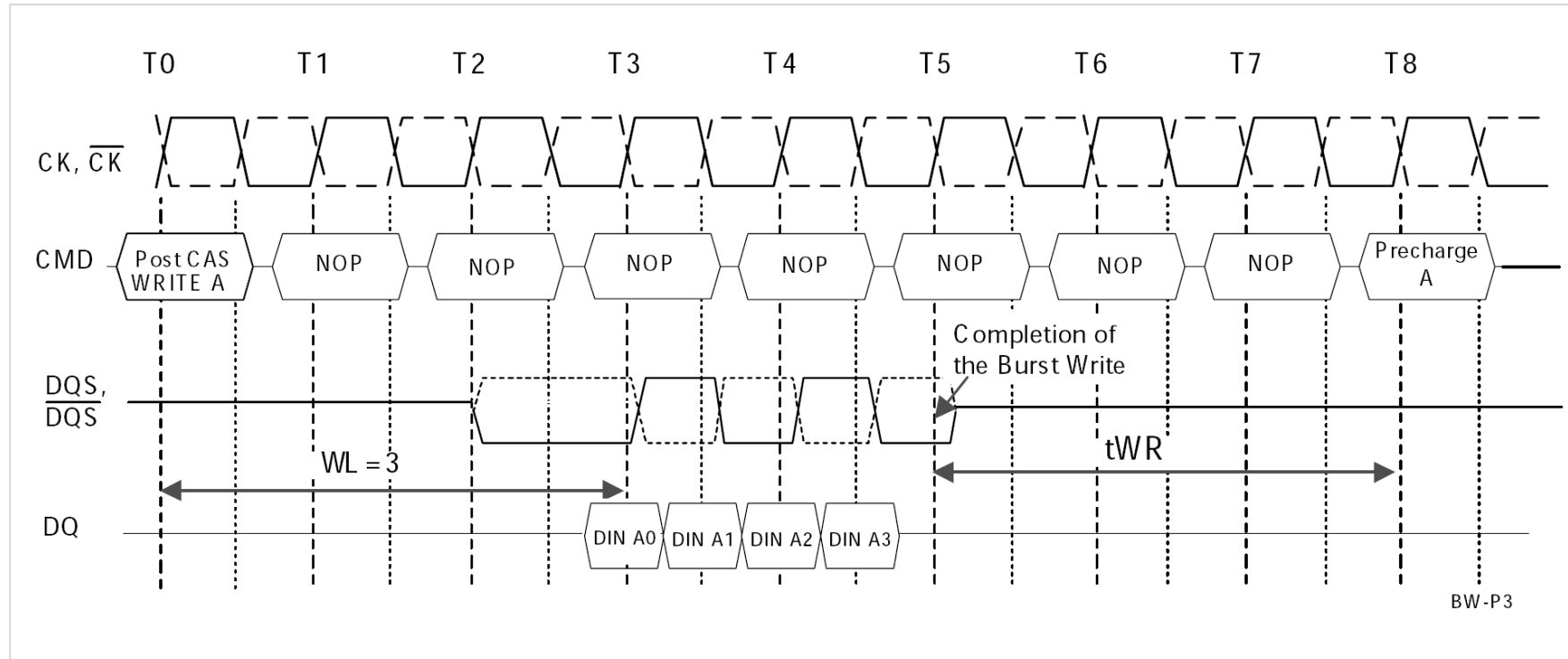

28. Burst Write followed by Precharge II:  $WL = (R L - 1) = 4, BL = 4, tWR = 3$

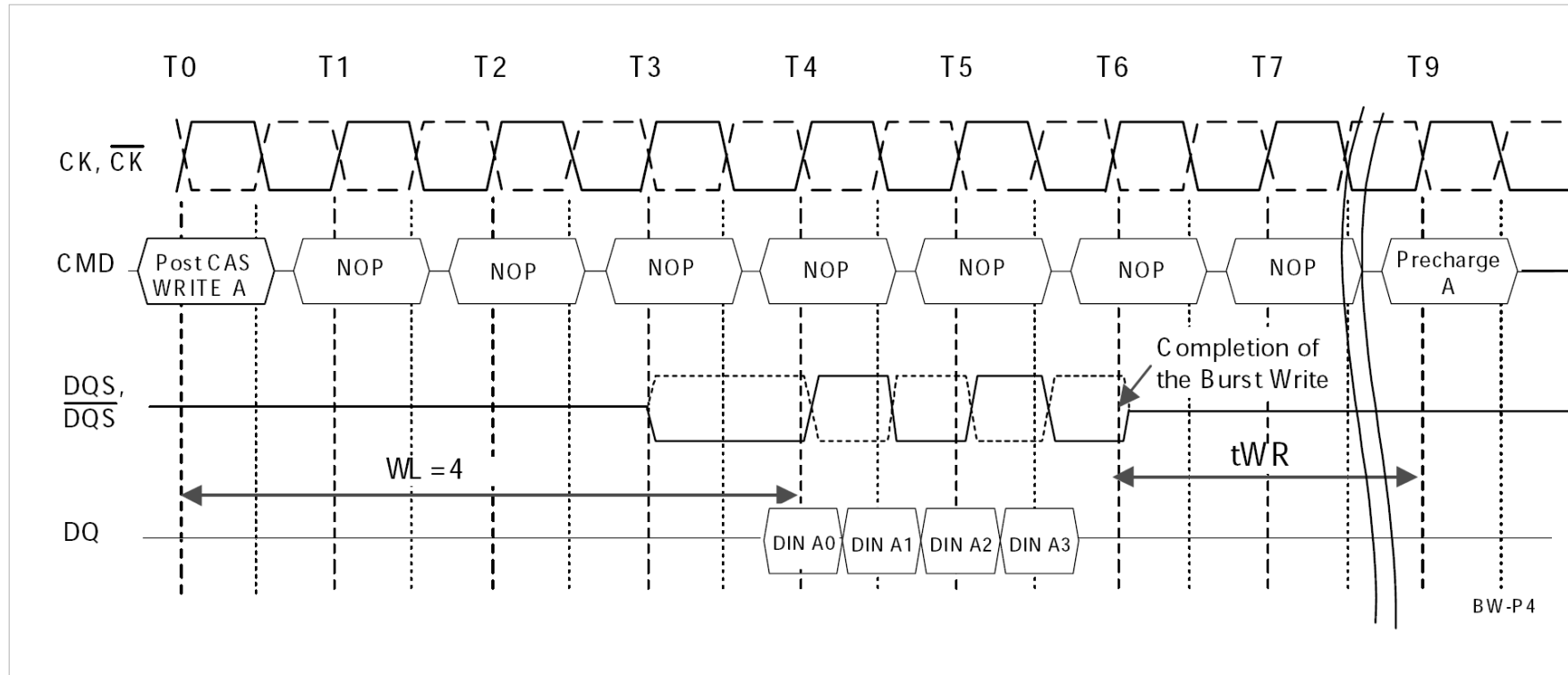

29. Burst Read with Auto-Precharge I: followed by an activation to the Same Bank (tRC Limit)

RL = 5 (AL = 2, CL = 3), BL = 4, tRTP <= 2 clocks

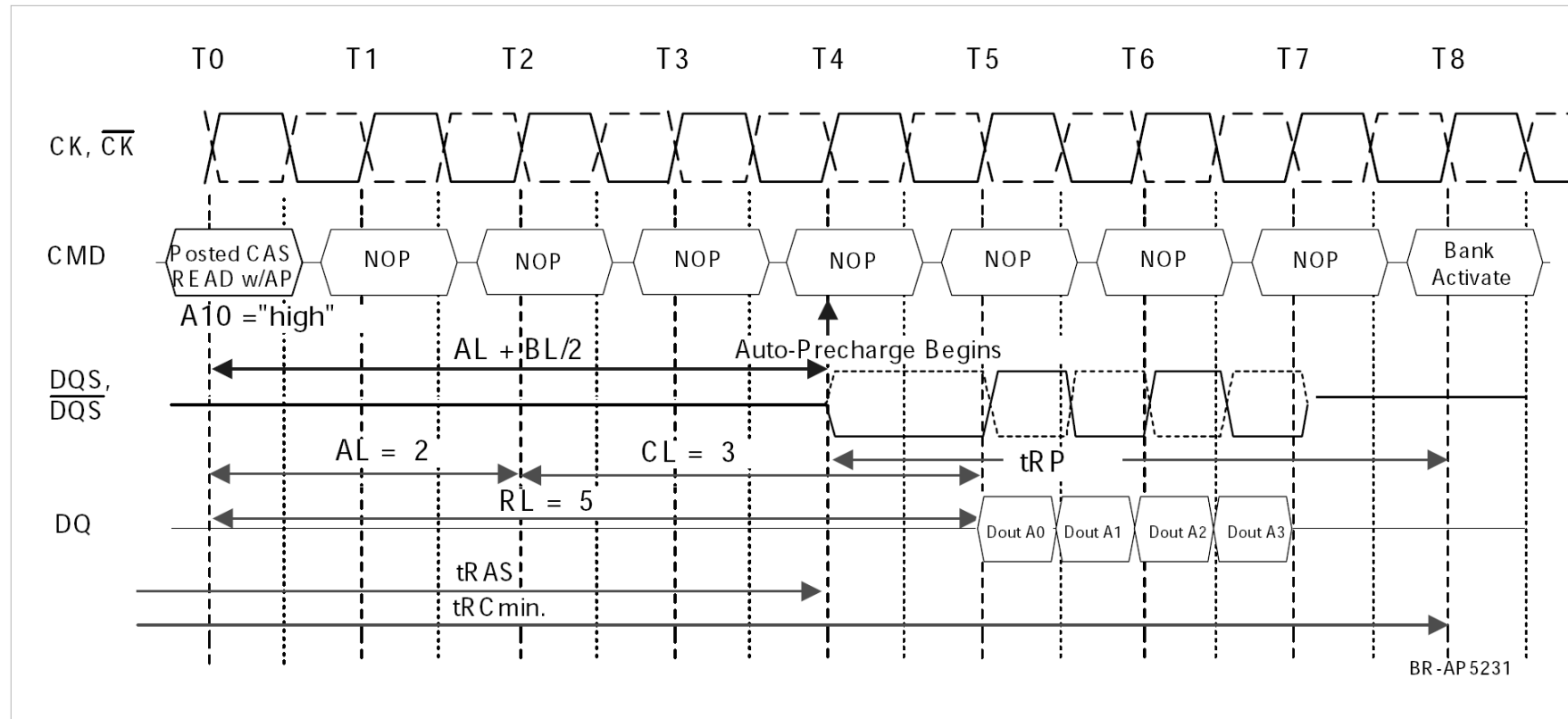

30. Burst Read with Auto-Precharge II: followed by an Activation to the Same Bank (tRAS Limit)

RL = 5 (AL = 2, CL = 3), BL = 4, tRTP <= 2 clocks

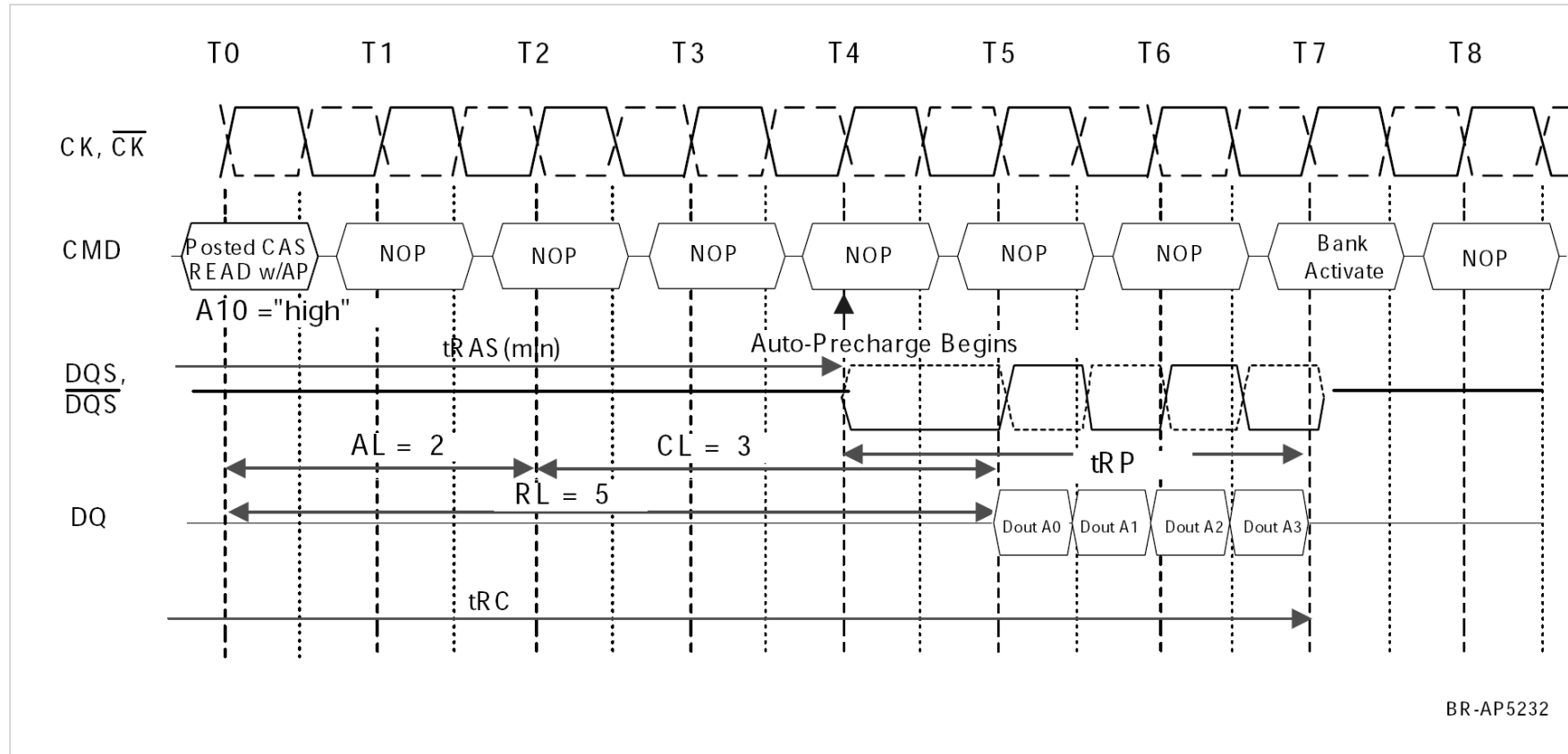

31. Burst Read with Auto-Precharge III: followed by an Activation to the Same Bank

RL=4(AL=1, CL=3), BL=8, tRTP<=2 clocks

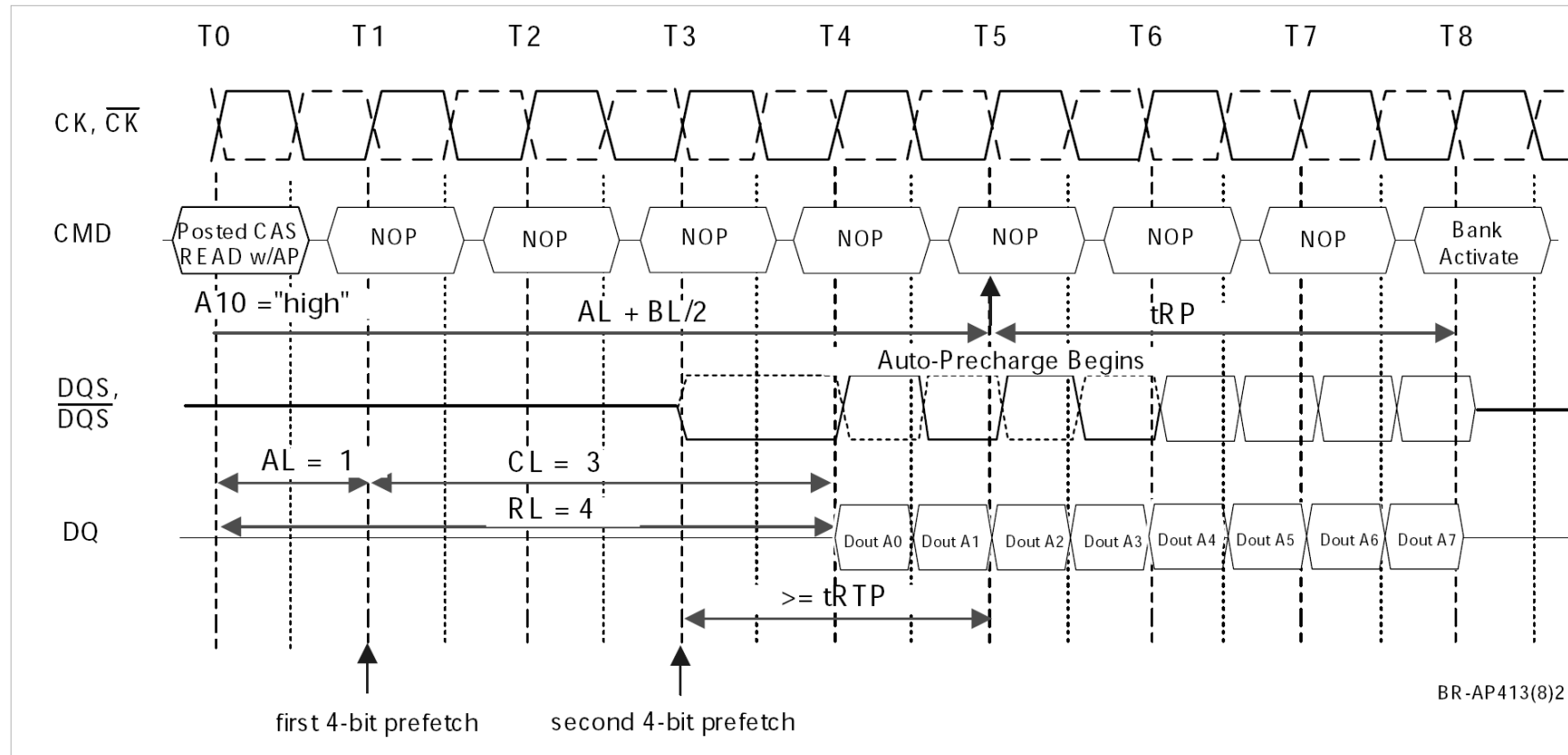

32. Burst Read with Auto-Precharge IV: followed by an Activation to the Same Bank

RL=4(AL=1, CL=3), BL=4, tRTP>2 clocks

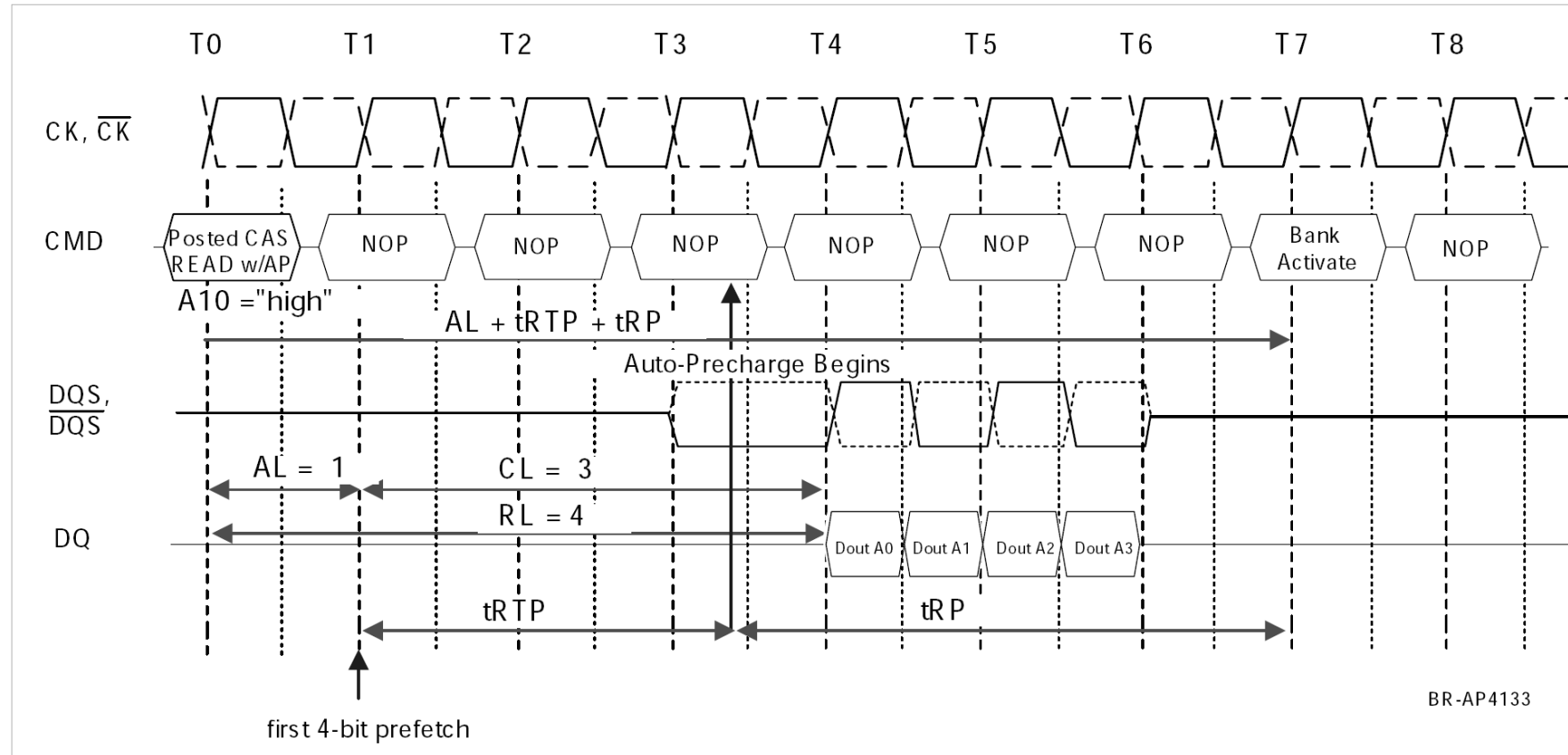

33. Burst Write with Auto-Precharge I:  $WL = 2, t_{DAL} = 6$  ( $WR = 3, t_{RP} = 3$ ),  $BL = 4$  tRC Limit)

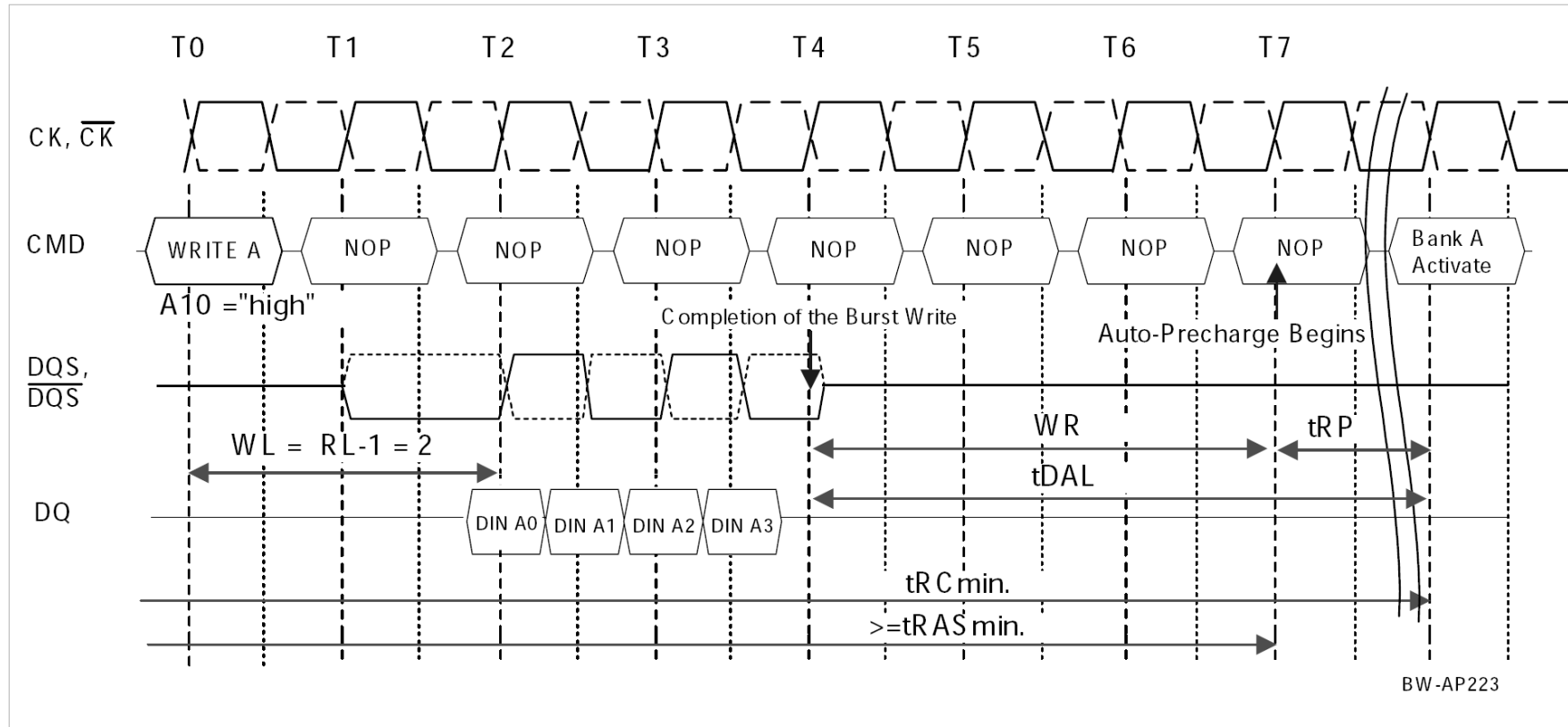

34. Burst Write with Auto-Precharge II:  $WL=4, tDAL=6(WR=3, tRP=3), BL=4$  ( $WR+tRP$  Limit)

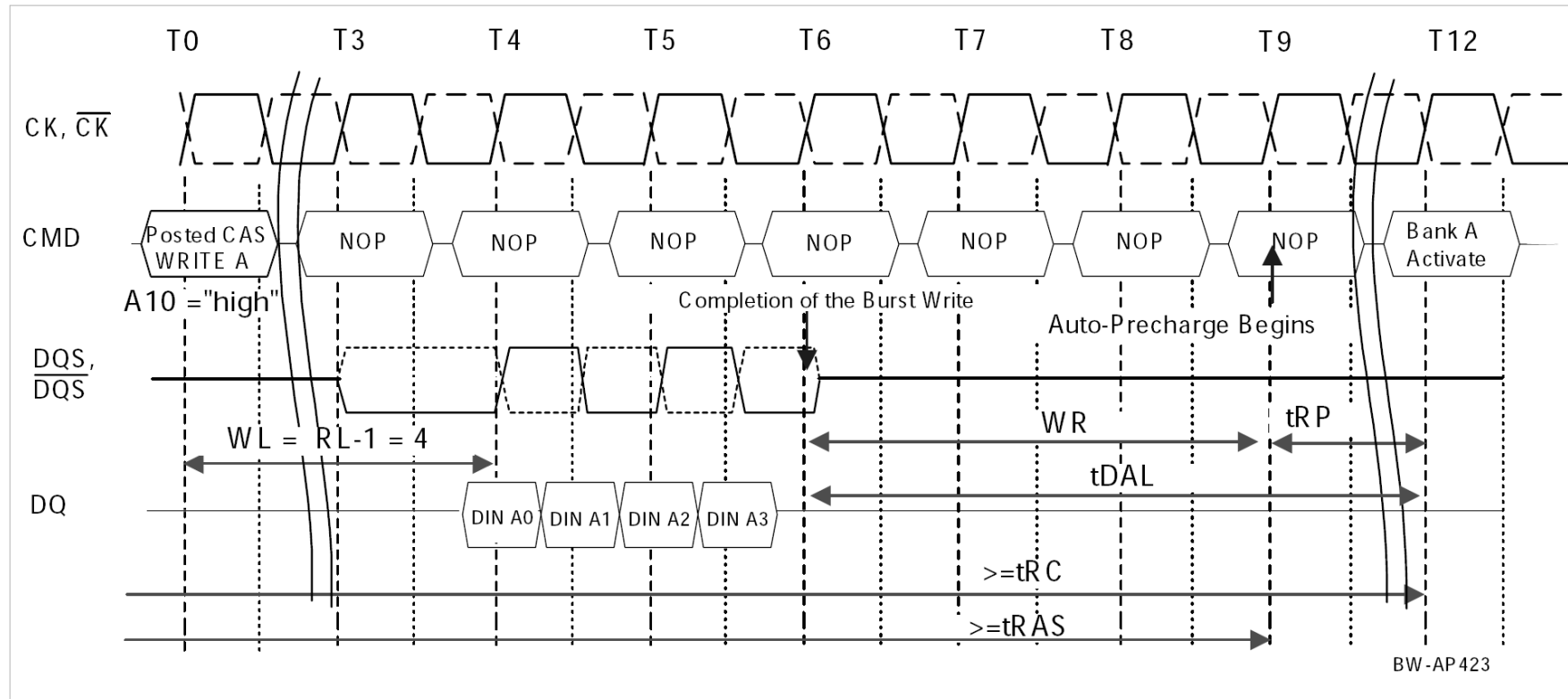

35. Auto-Refresh Command

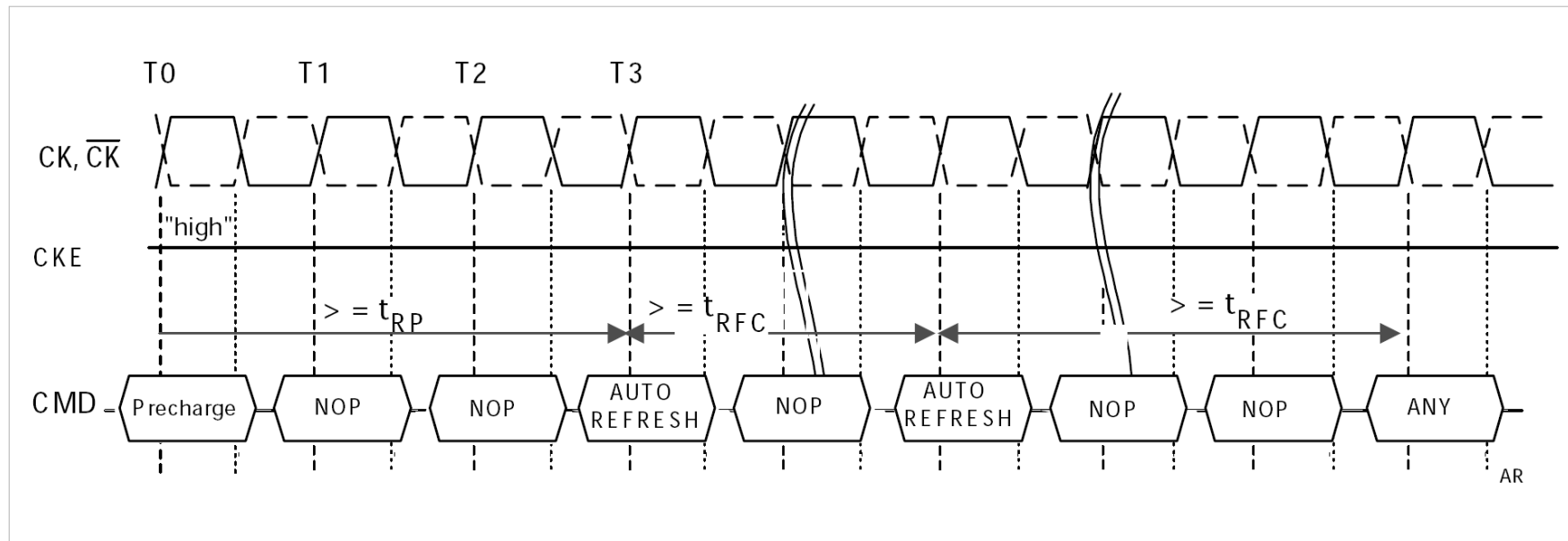

36. Self-Refresh Command

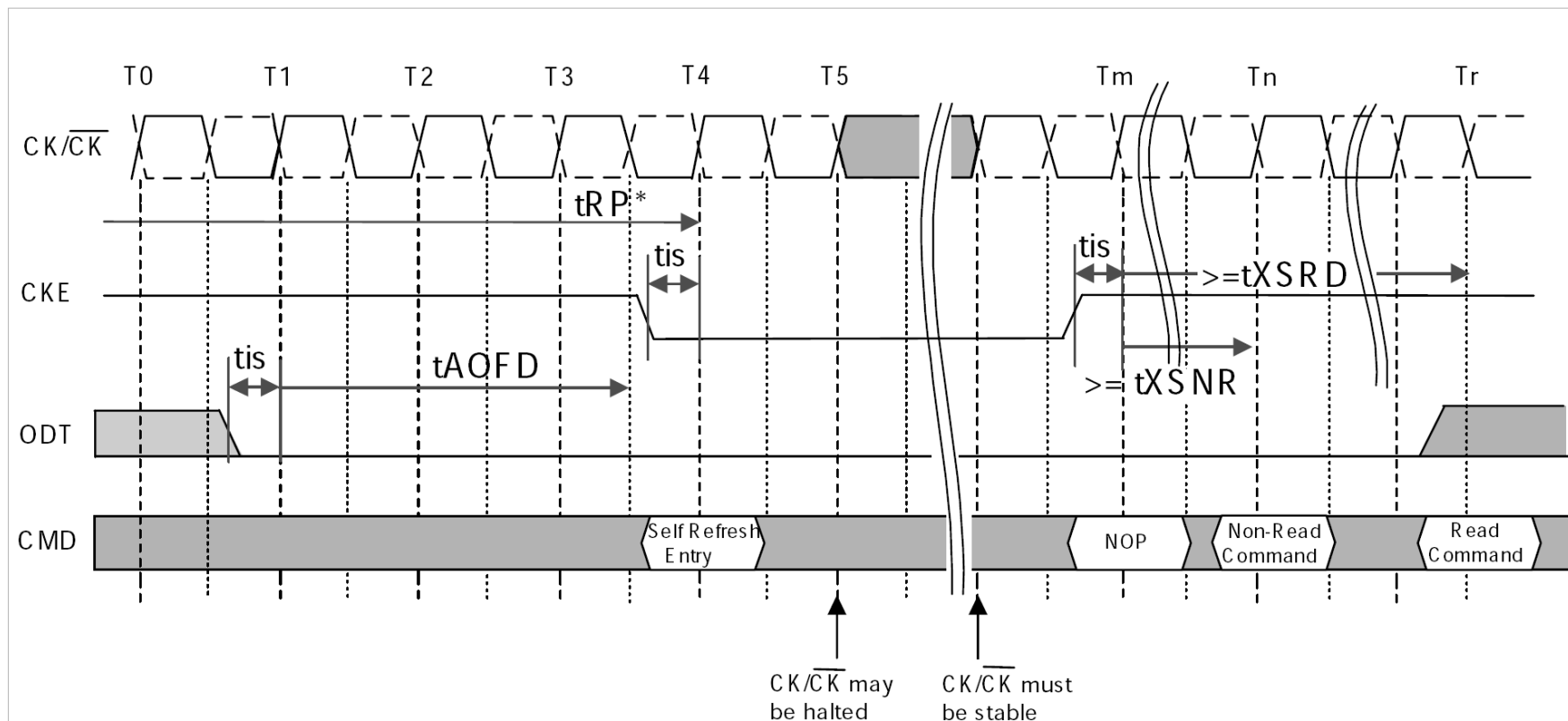

\* = Device must be in the "All banks idle" state to entering Self Refresh mode.  
 ODT must be turned off prior to entering Self Refresh mode.  
 tXSRD has to be satisfied for a Read or a Read with Auto-Precharge command.  
 tXSNR has to be satisfied for any command except a Read or a Read with Auto-Precharge command.

37. Active Power-Down Mode Entry I: and Exit after an Activate Command

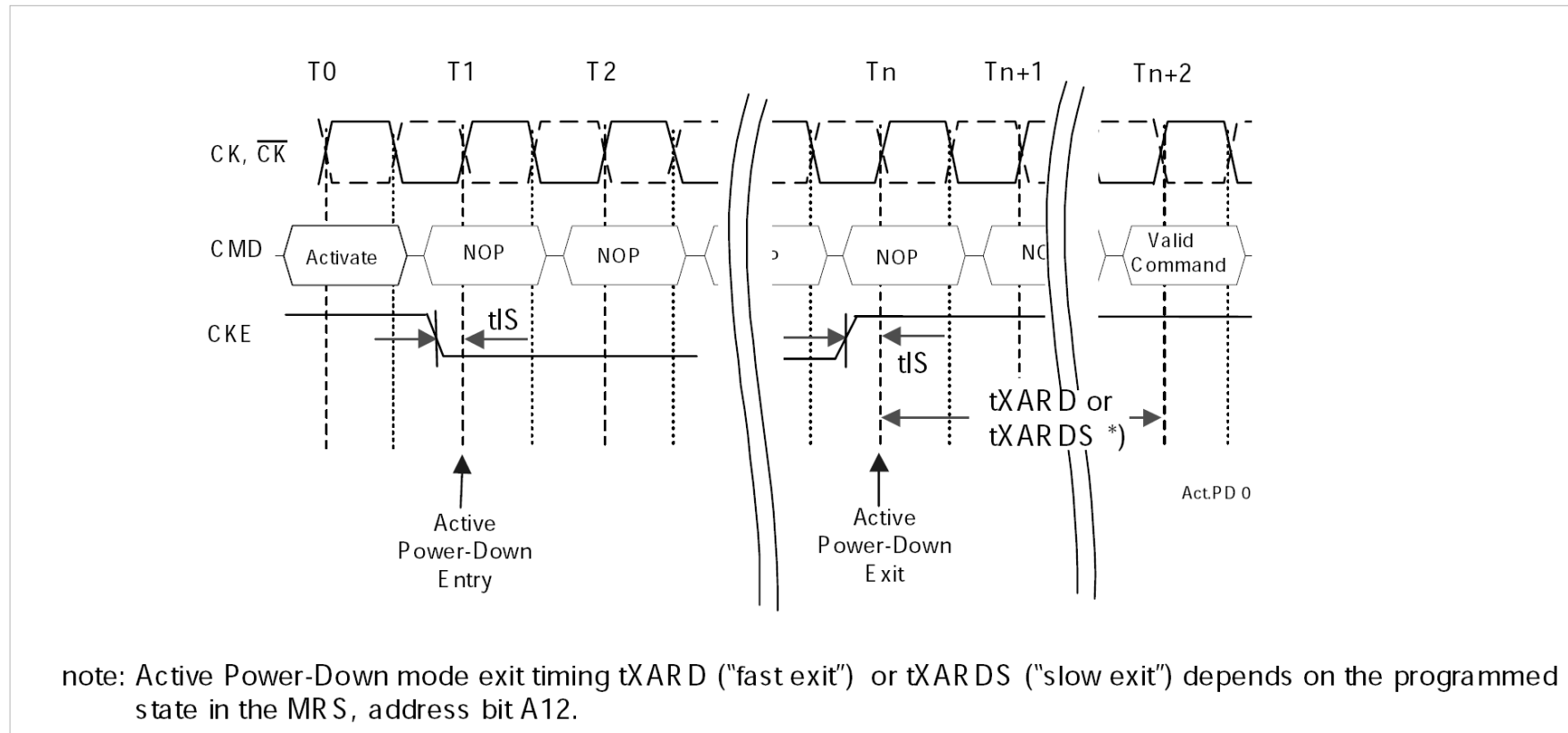

38. Active Power-Down Mode Entry II: and Exit after a Read Burs t: R L = 4 (AL = 1, CL =3), BL = 4

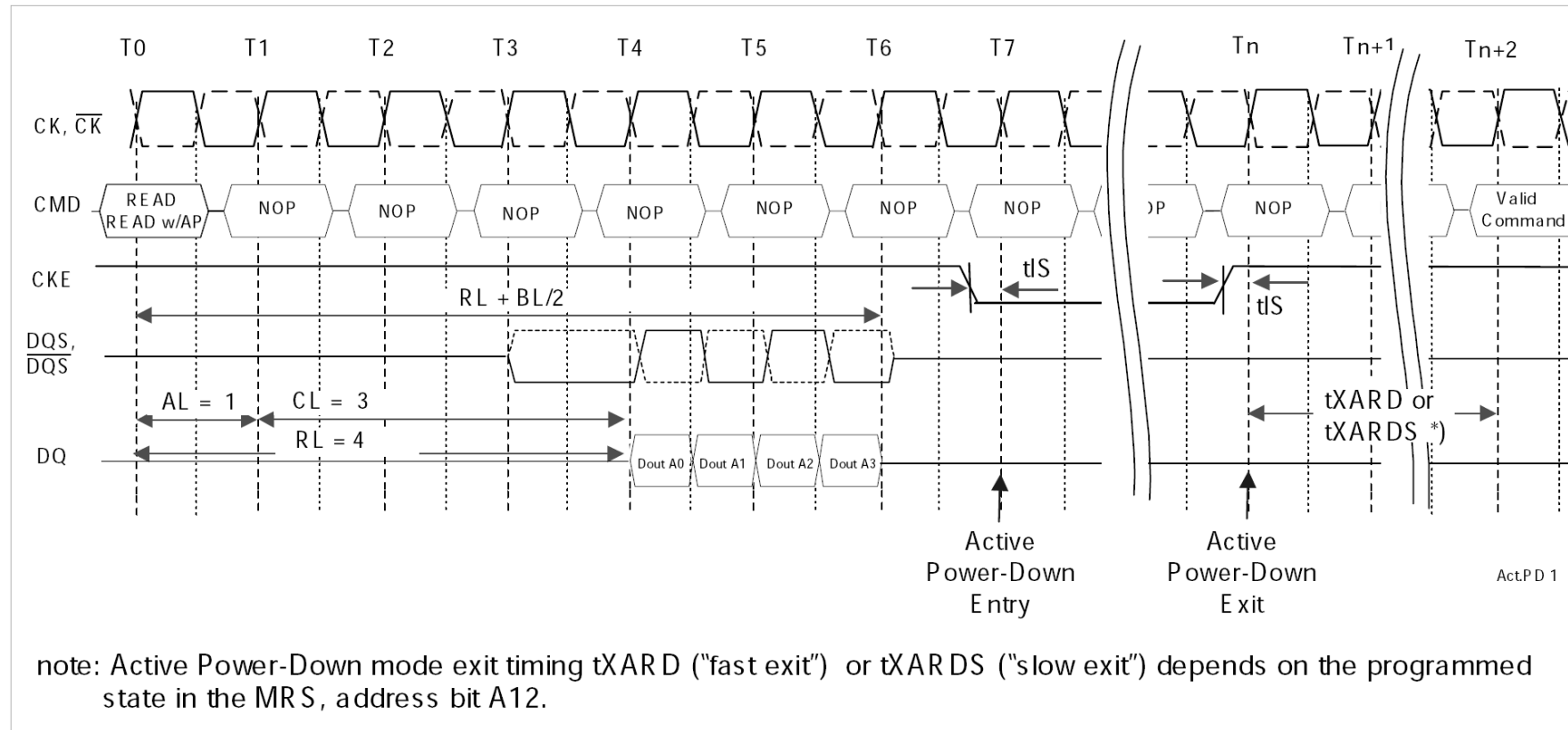

39. Active Power-Down Mode Entry III: and Exit after a Write Burst: WL = 2, tWTR = 2, BL = 4

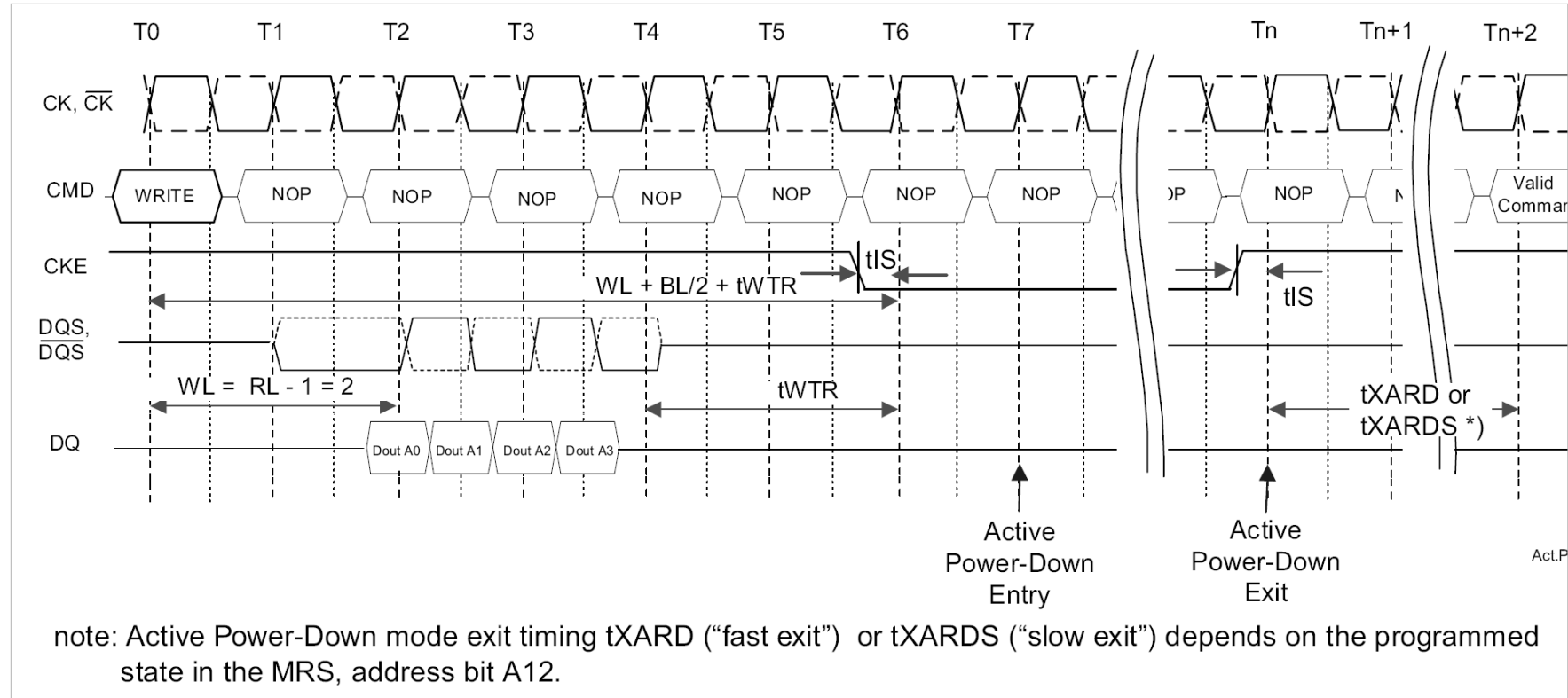

40. Precharge Power Down Mode Entry and Exit

