

---

## 250mA Ultra Low Dropout Linear Regulator

### Features

- Maximum Output Current: 250mA
- Highly Accurate: Output Voltage $\pm 2\%$
- Low Power Consumption: 2uA Typ.
- Small input/output differential:  
0.4V at 160mA ( $V_{OUT}=3.3V$ )  
0.12V at 100mA ( $V_{OUT}=5.0V$ )
- SOT-23 Package

### Applications

- Battery Powered Equipment
- Palmtops
- Portable Cameras and Video Recorders
- Reference Voltage Sources

### Description

The EP1201 series is a group of positive voltage output, three-pin regulators, that provides a high current even when the input/output voltage differential is small. Low power consumption and high accuracy is achieved through CMOS and programmable fuse technologies.

The EP1201 consists of a high-precision voltage reference, an error correction circuit, and a current limited output driver. Transient responses to load variations have improved in comparison to the existing series. SOT-23(150mW) package is available.

### Typical Application

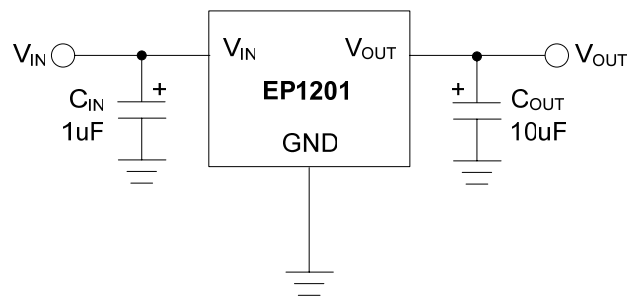

**Pin Assignment**

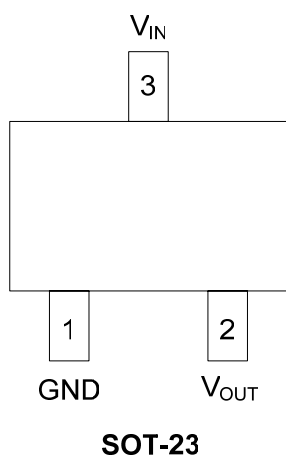

**Ordering Information**

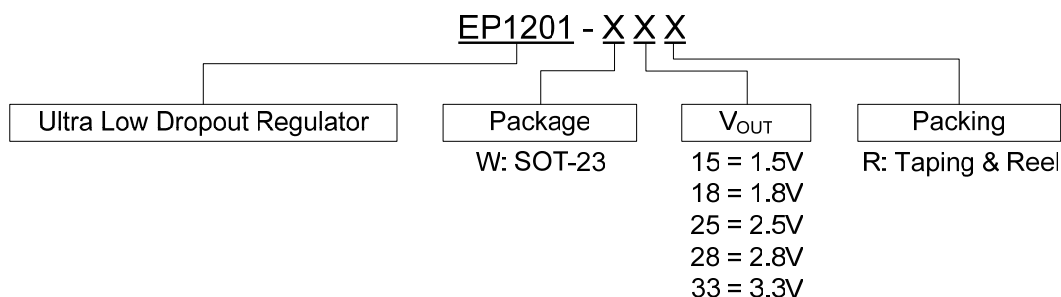

**Pin Description**

Pin	Name	Function
1	GND	Ground
2	V <sub>OUT</sub>	Output Voltage
3	V <sub>IN</sub>	Input Voltage

**Absolute Maximum Rating**

Symbol	Item	Rating	Units
V <sub>IN</sub>	Input Voltage	12	V
I <sub>OUT</sub>	Output Current	500	mA
V <sub>OUT</sub>	Output Voltage	GND-0.3~ V <sub>IN</sub> +0.3	V
P <sub>D</sub>	Continuous Total Power Dissipation	150	mW
T <sub>OPR</sub>	Operating Ambient Temperature Range	-30 ~ +80	°C
T <sub>STG</sub>	Storage Temperature Range	-40 ~ +125	°C
θ <sub>JA</sub>	Thermal Resistance (Junction-to-Ambient)	SOT-23 250	°C/W

**Electrical Characteristics**

Symbol	Parameter		Conditions	Min.	Typ.	Max.	Units	
$V_{OUT(E)}$ (Note 1)	Output Voltage		EP1201-18	$V_{IN}=2.8V, I_{OUT}=40mA$	1.764	1.800	1.836	V
			EP1201-33	$V_{IN}=4.3V, I_{OUT}=40mA$	3.234	3.300	3.366	
$I_{OUT(max)}$	Maximum Output Current		EP1201-18	$V_{IN}=2.8V, V_{OUT(E)} \geq 1.62V$	80			mA
			EP1201-33	$V_{IN}=4.3V, V_{OUT(E)} \geq 2.97V$	150			
$V_D$	Dropout Voltage (Note 2)	$V_{D1}$	EP1201-18	$I_{OUT}=40mA$		200	370	mV
		$V_{D2}$		$I_{OUT}=80mA$		450	710	
		$V_{D1}$	EP1201-33	$I_{OUT}=80mA$		200	360	
		$V_{D2}$		$I_{OUT}=160mA$		450	700	
$REG_{LINE}$	Line Regulation ( $\Delta V_{OUT}/\Delta V_{IN}\Delta V_{OUT}$ )		EP1201-18	$I_{OUT}=40mA, 2.8V \leq V_{IN} \leq 10V$		0.2	0.3	%V
			EP1201-33	$I_{OUT}=40mA, 4.3V \leq V_{IN} \leq 10V$		0.2	0.3	
$REG_{LOAD}$	Load Regulation ( $\Delta V_{OUT}$ )		EP1201-18	$V_{IN}=2.8V, 1mA \leq I_{OUT} \leq 40mA$		10	30	mV
			EP1201-33	$V_{IN}=4.3V, 1mA \leq I_{OUT} \leq 80mA$		20	50	
$I_S$	Supply Current		EP1201-18	$V_{IN}=2.8V$		3.0	5.0	$\mu A$
			EP1201-33	$V_{IN}=4.3V$		2.0	5.0	
$V_{IN}$	Input Voltage		EP1201-18		1.8		10	V
			EP1201-33		1.8		10	
	Output Voltage Temperature Characteristics ( $\Delta V_{OUT}/\Delta T_{OPR}\Delta V_{OUT}$ )		EP1201-18	$I_{OUT}=40mA, -40^\circ C \leq T_{OPR} \leq 85^\circ C$		$\pm 100$		ppm/ $^\circ C$
			EP1201-33	$I_{OUT}=40mA, -40^\circ C \leq T_{OPR} \leq 85^\circ C$		$\pm 100$		

**Note 1:**  $V_{OUT(E)}$  = Effective output voltage (i.e. the output voltage when “ $V_{OUT}+1.0V$ ” is provided while maintaining a certain  $I_{OUT}$  value.

**Note 2:**  $V_D = \{ V_{IN1}^{(Note 3)} - V_{OUT1}^{(Note 4)} \}$

**Note 3:** The input voltage at the time  $V_{OUT1}$  is output input voltage has been gradually reduced.

**Note 4:** A voltage equal to 98% of the output voltage when a stabilized ( $V_{OUT}+ 1.0V$ ) is input.

Typical Performance Characteristics

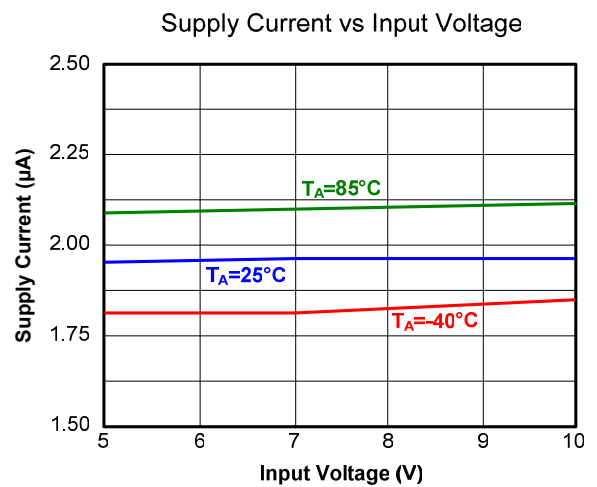
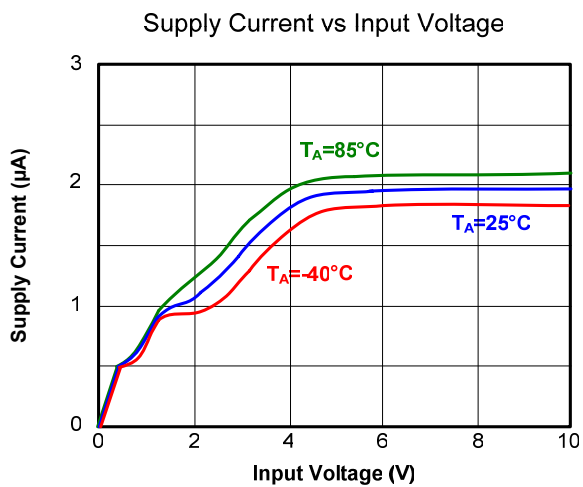
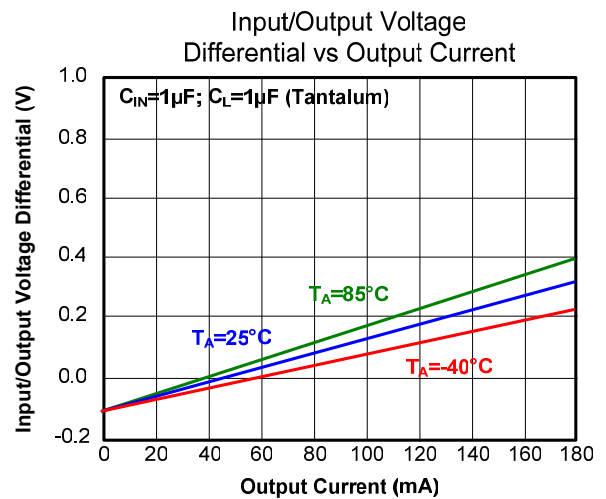
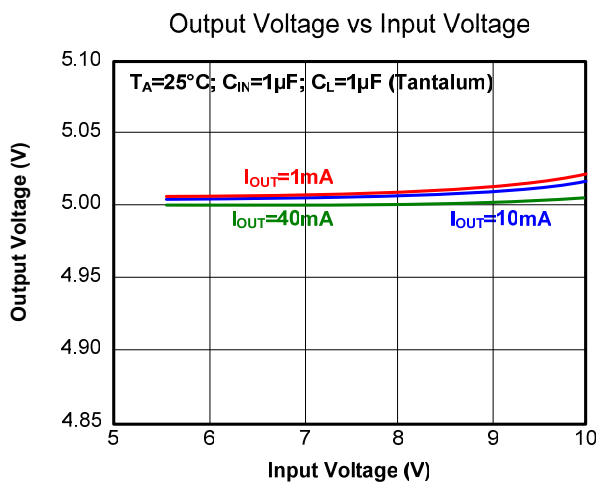
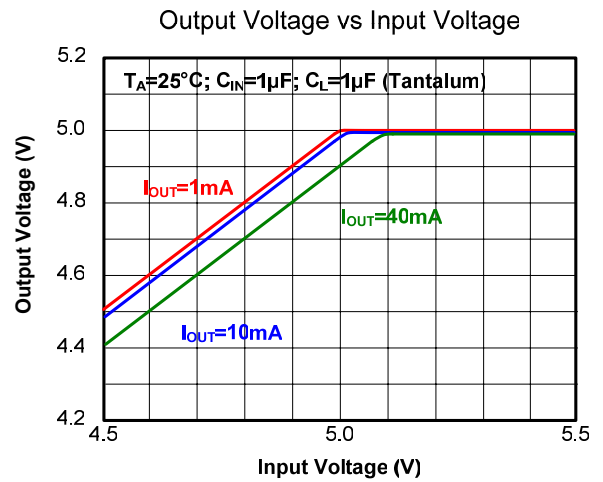
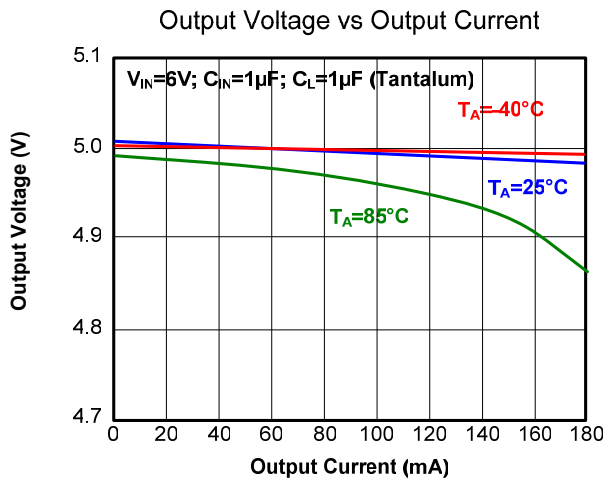

Typical Performance Characteristics (Continued)

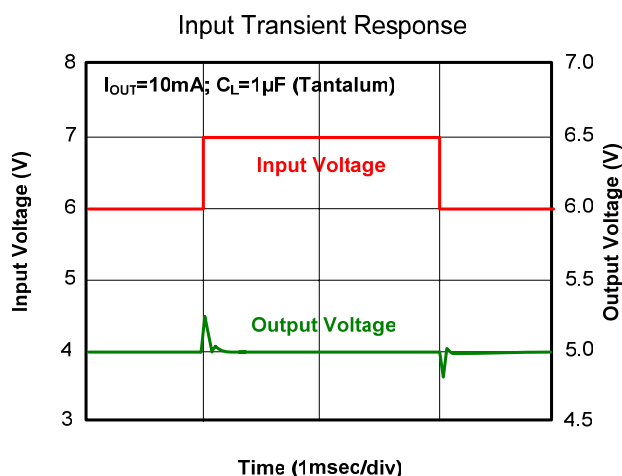
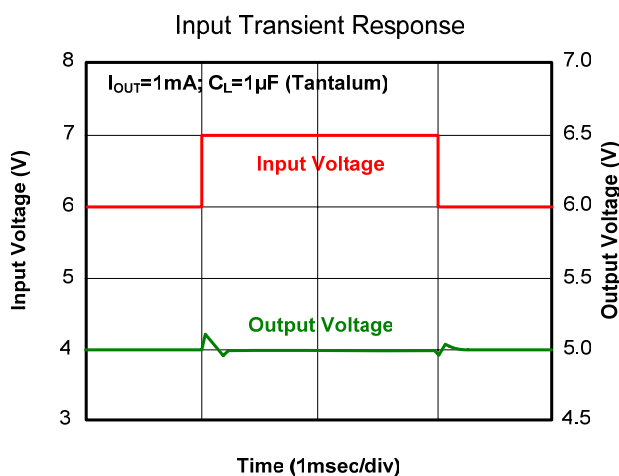
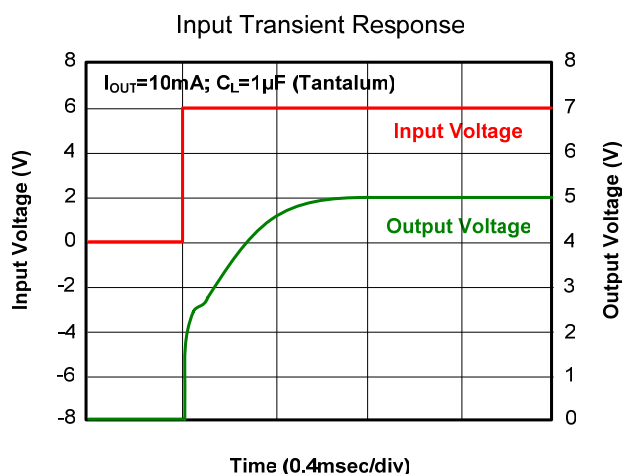
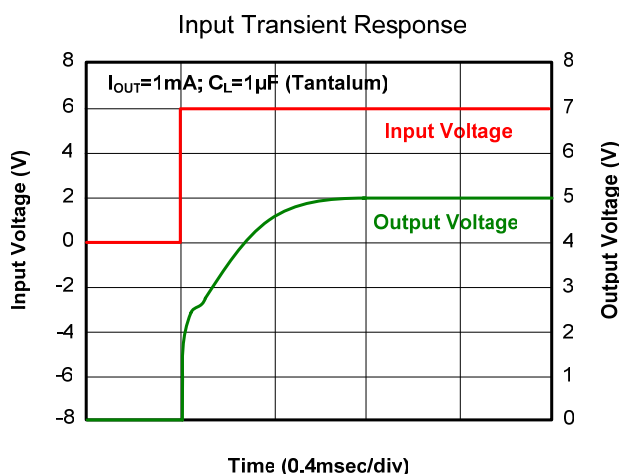
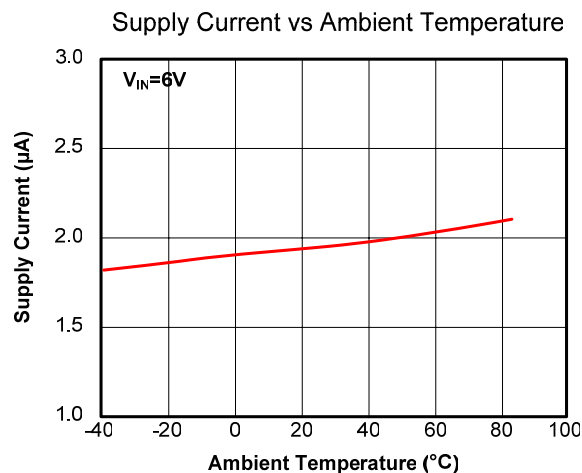
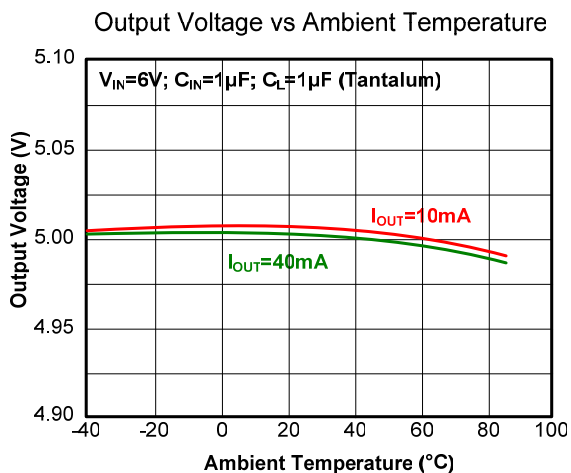

**Typical Performance Characteristics (Continued)**

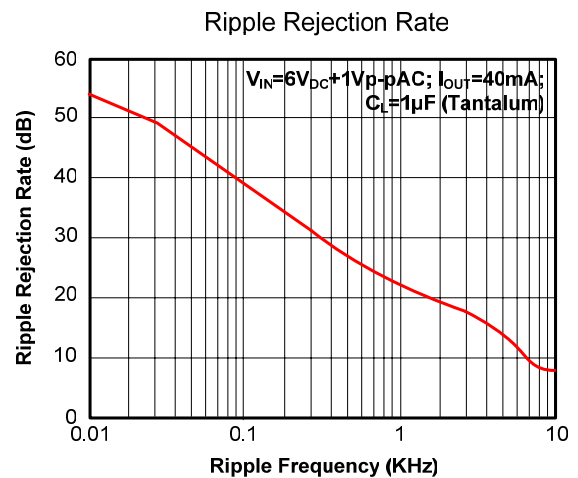
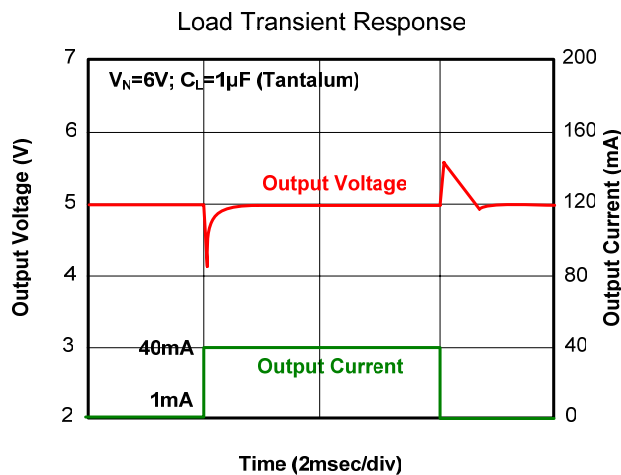

**Functional Block Diagram**

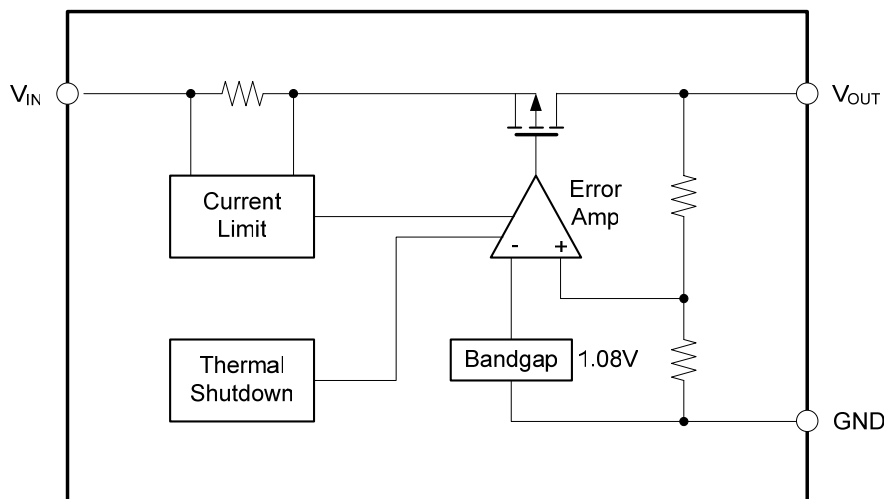

**Functional Description**

A minimum of  $10\mu F$  capacitor must be connected from  $V_{OUT}$  to ground to insure stability. Typically a large storage capacitor is connected from  $V_{IN}$  to ground to ensure that the input voltage does not sag below the minimum dropout voltage during the load transient response. This pin must always be 0.7V higher than  $V_{OUT}$  in order for the device to regulate properly.

**Marking Information**

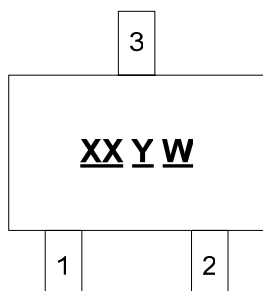

SOT-23

**XX** : Identification Code  
(See Appendix)

**YW** : Assembly Date

**Y** : Year

**W** : Week

(See "Date Code Convention")

**Appendix**

Identification Code	Part Number	V <sub>OUT</sub>
<b>BB</b>	EP1201	1.5V
<b>BC</b>	EP1201	1.8V
<b>BD</b>	EP1201	2.5V
<b>BE</b>	EP1201	2.8V
<b>BF</b>	EP1201	3.3V

**Date Code Convention**

Y	Year	2005	2006	2007	2008	2009	2010	2011	2012	2013	2014
	Mark	<b>5</b>	<b>6</b>	<b>7</b>	<b>8</b>	<b>9</b>	<b>0</b>	<b>1</b>	<b>2</b>	<b>3</b>	<b>4</b>
	Year	2015	2016	2017	2018	2019	2020	2021	2022	2023	2024
	Mark	<b>A</b>	<b>B</b>	<b>C</b>	<b>D</b>	<b>E</b>	<b>F</b>	<b>G</b>	<b>H</b>	<b>J</b>	<b>K</b>
W	Week	1	2	3	4	5	6	7	8	9	10
	Mark	<b>1</b>	<b>2</b>	<b>3</b>	<b>4</b>	<b>5</b>	<b>6</b>	<b>7</b>	<b>8</b>	<b>9</b>	<b>a</b>
	Week	11	12	13	14	15	16	17	18	19	20
	Mark	<b>b</b>	<b>c</b>	<b>d</b>	<b>e</b>	<b>f</b>	<b>g</b>	<b>h</b>	<b>i</b>	<b>j</b>	<b>k</b>
	Week	21	22	23	24	25	26	27	28	29	30
	Mark	<b>m</b>	<b>n</b>	<b>p</b>	<b>q</b>	<b>r</b>	<b>s</b>	<b>t</b>	<b>u</b>	<b>v</b>	<b>w</b>
	Week	31	32	33	34	35	36	37	38	39	40
	Mark	<b>x</b>	<b>y</b>	<b>z</b>	<b>A</b>	<b>B</b>	<b>C</b>	<b>D</b>	<b>E</b>	<b>F</b>	<b>G</b>
	Week	41	42	43	44	45	46	47	48	49	50
	Mark	<b>H</b>	<b>J</b>	<b>K</b>	<b>L</b>	<b>M</b>	<b>N</b>	<b>P</b>	<b>Q</b>	<b>R</b>	<b>S</b>
	Week	51	52								
	Mark	<b>T</b>	<b>U</b>								

Package Description

SOT-23

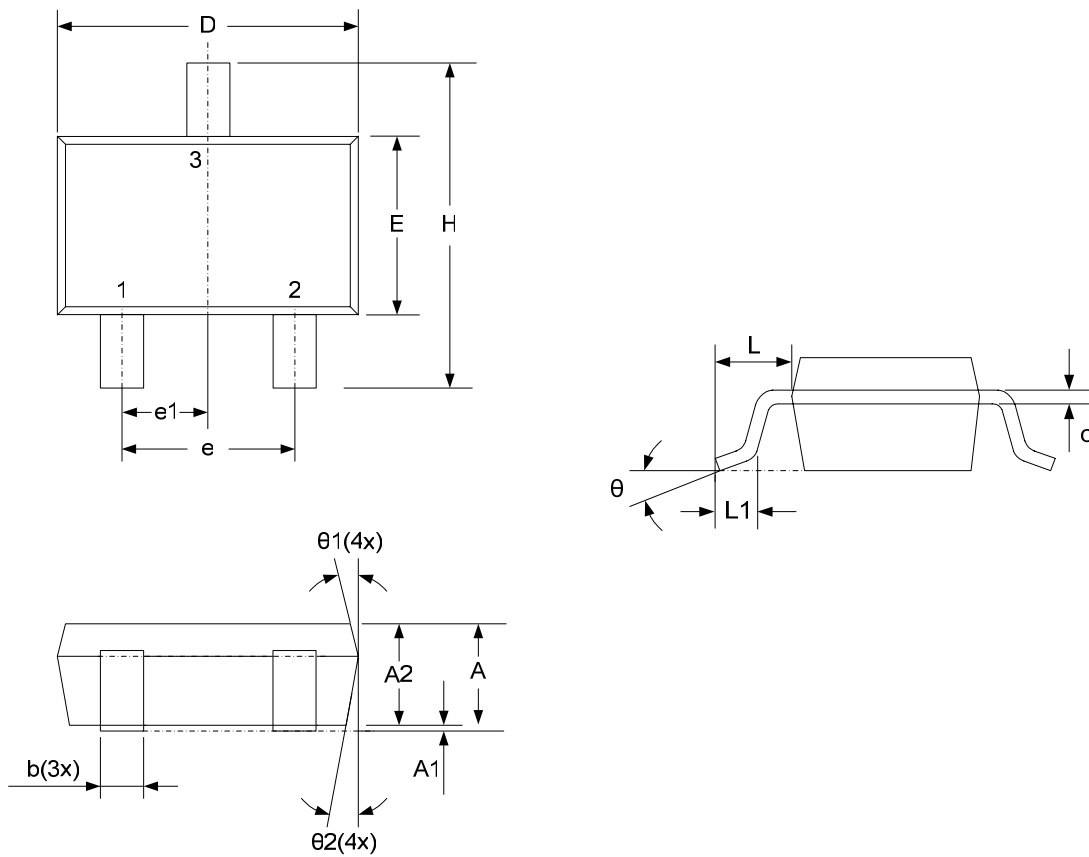

DIM	MILLIMETERS			INCHES		
	MIN.	NOM.	MAX.	MIN.	NOM.	MAX.
A	1.05	–	1.35	0.041	–	0.053
A1	0.05	–	0.15	0.002	–	0.006
A2	1.00	1.10	1.20	0.039	0.043	0.047
b	0.25	–	0.50	0.010	–	0.020
c	0.08	–	0.20	0.003	–	0.008
D	2.70	2.90	3.00	0.106	0.114	0.118
E	1.50	1.60	1.70	0.059	0.063	0.067
H	2.60	2.80	3.00	0.102	0.110	0.118
e	1.80	1.90	2.00	0.071	0.075	0.079
e1	0.85	0.95	1.05	0.033	0.037	0.041
L	0.50	0.60	0.70	0.020	0.024	0.028
L1	0.30	–	0.60	0.012	–	0.024
$\theta$	0°	5°	10°	0°	5°	10°
$\theta 1$	3°	5°	7°	3°	5°	7°
$\theta 2$	6°	8°	10°	6°	8°	10°